

E

# Thermoplastic Conveyor Chains

2006



**MAGRIS**

# Contents

<b>Materials</b> .....	Page 2
<b>Thermoplastic straight running chains - Single hinge</b>	
820 Series .....	Page 4
831 Series .....	Page 7
<b>Thermoplastic straight running chains - Double hinge</b>	
821 Series .....	Page 8
<b>Thermoplastic sideflexing chains</b>	
880 Series .....	Page 9
879 Series .....	Page 10
880 TAB Series .....	Page 10
879 TAB Series .....	Page 12
880 BO Series .....	Page 13
879 BO Series .....	Page 14
878 BO Series .....	Page 14
<b>Thermoplastic sideflexing chains on magnetic tracks</b>	
880 M Series .....	Page 15
879 M Series .....	Page 15
<b>Thermoplastic sideflexing chains</b>	
882 Series .....	Page 16
882 TAB Series .....	Page 17
<b>Vacuum thermoplastic straight running chains - Single hinge</b>	
820 Vacuum Series .....	Page 18
<b>Vacuum thermoplastic sideflexing chains</b>	
880 TAB Vacuum Series .....	Page 19
<b>Thermoplastic sideflexing chains</b>	
780 Series .....	Page 20
790 Series .....	Page 20
<b>Straight running chains with thermoplastic Top Plates</b>	
843 Series .....	Page 21
845 Series .....	Page 22
863 Series .....	Page 22
963 Series .....	Page 23

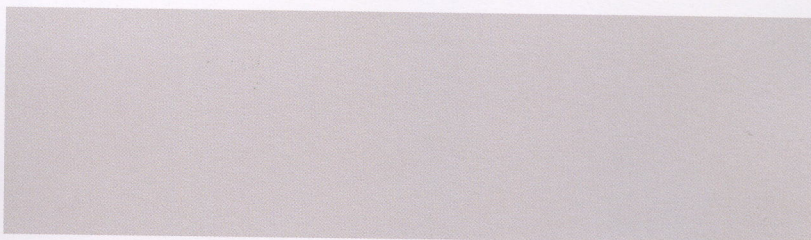

<b>“1843” Sideflexing chains with thermoplastic Top Plates</b>	
1843 Series .....	Page 24
<b>“1873” Sideflexing chains with thermoplastic Top Plates</b>	
1873 Series .....	Page 25
<b>Thermoplastic straight running chains with rubber inserts - Single hinge</b>	
HFL 820 Series .....	Page 26
<b>Thermoplastic straight running chains with rubber inserts - Double hinge</b>	
HFL 821 Series .....	Page 27
<b>Thermoplastic sideflexing chains with rubber inserts</b>	
HFL 880 TAB Series .....	Page 28
HFL 880 BO Series .....	Page 28
HFL 878 BO Series .....	Page 29
HFL 882 TAB Series .....	Page 29
<b>“1873” Sideflexing chains with thermoplastic Top Plates and rubber inserts</b>	
HFL 1873 TAB Series .....	Page 30
<b>Biplanar thermoplastic chains</b>	
WLF 1700 Series .....	Page 31
WLF 1700 TAB Series .....	Page 31
WLF 1701 Series .....	Page 32
WLF 1701 TAB Series .....	Page 32
WLF 1702 Series .....	Page 33
<b>Case conveyor chains</b>	
D 600 Series .....	Page 34
D 600 C Series .....	Page 34
D 1400 Series .....	Page 35
<b>Plastic corrosion resistance table .....</b>	Page 36

2006



**Thermoplastic  
Conveyor Chains**

# Thermoplastic straight running chains - Single hinge

## 820 Series

Thermoplastic straight running chains - Single hinge

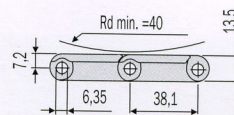
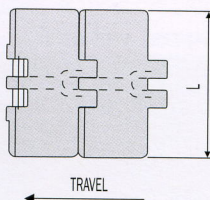
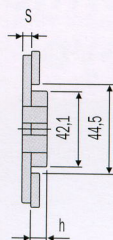
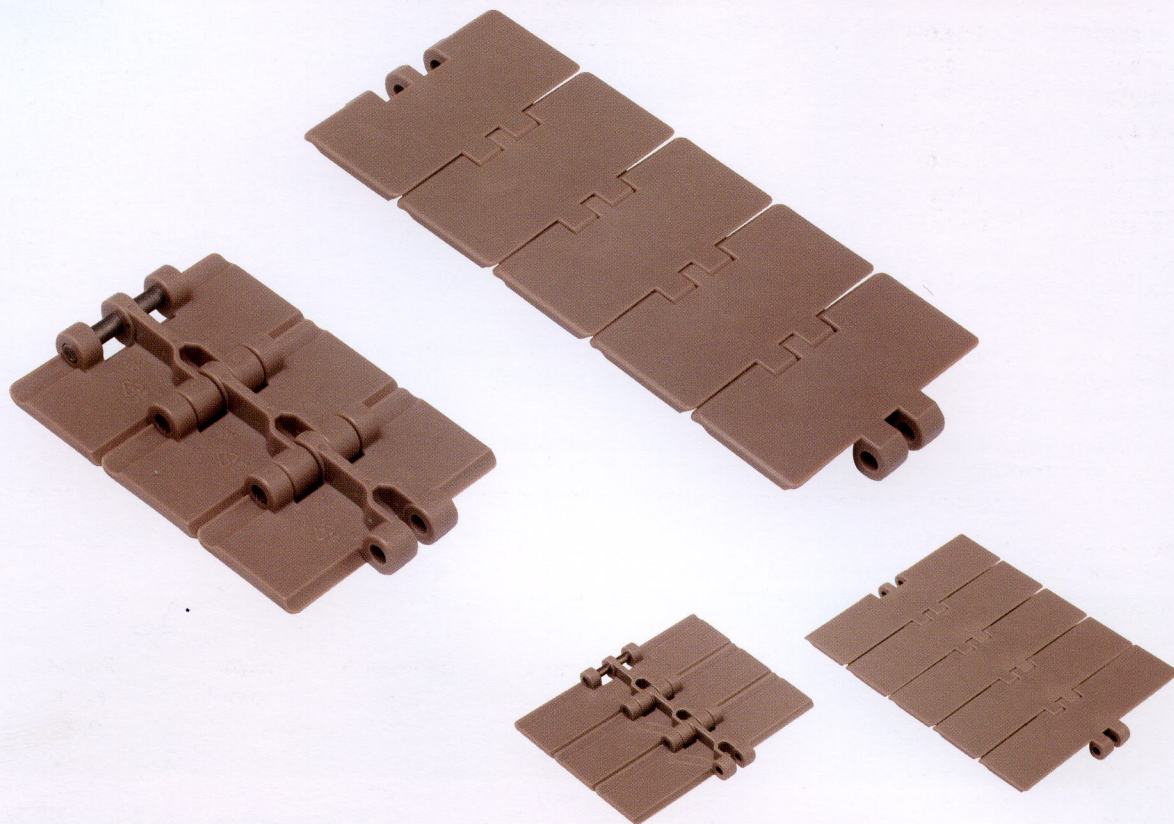

### 820 D

#### Acetal Resin

- Plates in self-lubricating acetal resin, grey-coloured.
- Pins in special chrome-nickel stainless steel, work hardened for high resistance.

Chain Ref.	Magris code	Material	Width L mm.	Thickness S mm.	Height h mm.	Weight Kg/m
D 820 - K 250	6.00.020	D Acetal resin (Grey)	63,5	4	9,5	0,73
D 820 - K 325	6.00.040		82,5			0,83
D 820 - K 343	6.00.043		87,0			0,85
D 820 - K 350	6.00.060		88,9			0,87
D 820 - K 400	6.00.070		101,6			0,95
D 820 - K 450	6.00.080		114,3			1,03
D 820 - K 600	6.00.100		152,4			1,25
D 820 - K 750	6.00.110		190,5			1,47

- Standard shipping lengths = 80 pitches = 10 feet = 3,048 metres.

- The above-mentioned chains can also be produced in acetal resin, white-coloured.

- These chains can be supplied either with pins in austenitic stainless steel, work hardened, highly wear resistant, or with pins in thermoplastic resin.

## 820 LFA

### Low Friction Acetal Resin

- Plates in self-lubricating low friction acetal resin, light brown-coloured.
- Pins in special chrome-nickel stainless steel, work hardened for high resistance.

Chain Ref.	Magris code	Material	Width L mm.	Thickness S mm.	Height h mm.	Weight Kg/m
LFA 820 - K 250	6.10.020	LFA Acetal resin (Light brown)	63,5	4	9,5	0,73
LFA 820 - K 325	6.10.040		82,5			0,83
LFA 820 - K 330	6.10.042		83,8			0,83
LFA 820 - K 343	6.10.043		87,0			0,85
LFA 820 - K 350	6.10.060		88,9			0,87
LFA 820 - K 400	6.10.070		101,6			0,95
LFA 820 - K 450	6.10.080		114,3			1,03
LFA 820 - K 600	6.10.100		152,4			1,25
LFA 820 - K 750	6.10.110		190,5			1,47

- Standard shipping lengths = 80 pitches = 10 feet = 3,048 metres.

- These chains can be supplied either with pins in austenitic stainless steel, work hardened, highly wear resistant, or with pins in thermoplastic resin.

## 820 SP

### Super Performance Acetal Resin

- Plates in self-lubricating very low friction acetal resin, dark grey-coloured.
- Pins in special chrome-nickel stainless steel, work hardened for high resistance.

Chain Ref.	Magris code	Material	Width L mm.	Thickness S mm.	Height h mm.	Weight Kg/m
SP 820 - K 325	6.20.040	SP Acetal resin (Dark grey)	82,5	4	9,5	0,83
SP 820 - K 343	6.20.043		87,0			0,85
SP 820 - K 350	6.20.060		88,9			0,87
SP 820 - K 400	6.20.070		101,6			0,95
SP 820 - K 450	6.20.080		114,3			1,03
SP 820 - K 600	6.20.100		152,4			1,25
SP 820 - K 750	6.20.110		190,5			1,47

- Standard shipping lengths = 80 pitches = 10 feet = 3,048 metres.

- These chains can be supplied either with pins in austenitic stainless steel, work hardened, highly wear resistant, or with pins in thermoplastic resin.

## 820 AS

### Antistatic Acetal Resin

- Plates in antistatic conductive acetal resin, black-coloured.
- Pins in special chrome-nickel stainless steel, work hardened for high resistance.

Chain Ref.	Magris code	Material	Width L mm.	Thickness S mm.	Height h mm.	Weight Kg/m
AS 820 - K 325	6.30.040	AS Acetal resin (Black)	82,5	4	9,5	0,83
AS 820 - K 350	6.30.060		88,9			0,87
AS 820 - K 400	6.30.070		101,6			0,95
AS 820 - K 450	6.30.080		114,3			1,03
AS 820 - K 600	6.30.100		152,4			1,25
AS 820 - K 750	6.30.110		190,5			1,47

- Standard shipping lengths = 80 pitches = 10 feet = 3,048 metres.

- These chains can be supplied with pins in austenitic stainless steel, work hardened, highly wear resistant, or with pins in thermoplastic resin.

## 820 PPB

### Chemical Resistant Reinforced Polypropylene

- Plates in chemical resistant reinforced polypropylene, white-coloured.
- Pins in chrome-nickel austenitic stainless steel (18% Chrome – 8% Nickel), work hardened for high resistance.

Chain Ref.	Magris code	Material	Width L mm.	Thickness S mm.	Height h mm.	Weight Kg/m
PPB 820 - K 325	6.40.040	PPB Reinforced polypropylene (White)	82,5	4	9,5	0,70
PPB 820 - K 350	6.40.060		88,9			0,74
PPB 820 - K 400	6.40.070		101,6			0,82
PPB 820 - K 450	6.40.080		114,3			0,90
PPB 820 - K 600	6.40.100		152,4			1,05
PPB 820 - K 750	6.40.110		190,5			1,20

- Standard shipping lengths = 80 pitches = 10 feet = 3,048 metres.

- These chains can be supplied either with pins in austenitic stainless steel, 316 series, work hardened, highly wear resistant, or with pins in thermoplastic resin.

## 820 WR

### Wear Resistant Resin

- Plates in thermoplastic wear resistant acetal resin, light grey-coloured.
- Pins in special chrome-nickel stainless steel, work hardened for high resistance.

Chain Ref.	Magris code	Material	Width L mm.	Thickness S mm.	Height h mm.	Weight Kg/m
WR 820 - K 325	6.50.040	WR Special acetal resin (Light grey)	82,5	4	9,5	0,83
WR 820 - K 400	6.50.070		101,6			0,95
WR 820 - K 450	6.50.080		114,3			1,03
WR 820 - K 600	6.50.100		152,4			1,05
WR 820 - K 750	6.50.110		190,5			1,47

- Standard shipping lengths = 80 pitches = 10 feet = 3,048 metres.

- These chains can be supplied either with pins in austenitic stainless steel, work hardened, highly wear resistant, or with pins in thermoplastic resin.

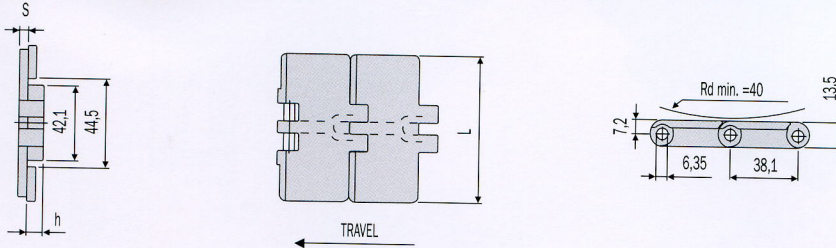
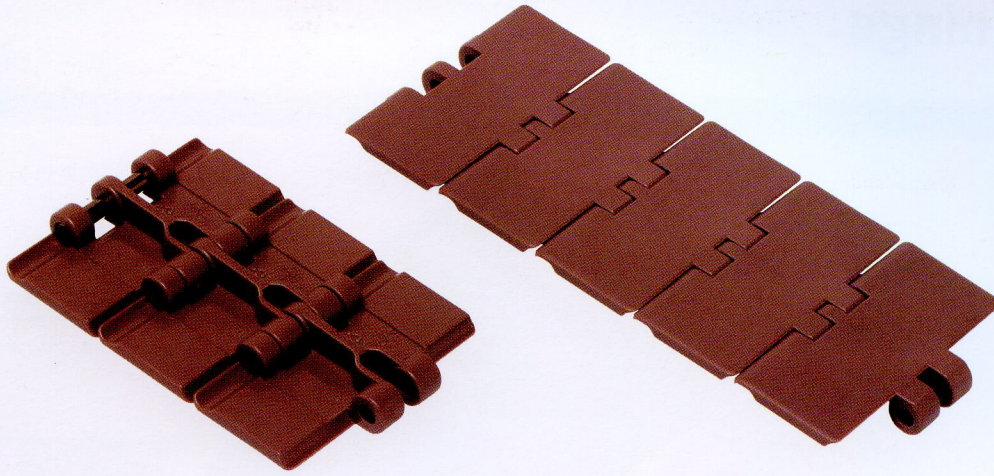

Thermoplastic straight running chains - Single hinge

### 831 LFA

#### Low Friction Acetal Resin

- Plates in self-lubricating low friction acetal resin, light brown-coloured.
- Pins in special chrome-nickel stainless steel, work hardened for high resistance.

Chain Ref.	Magris code	Material	Width L mm.	Thickness S mm.	Height h mm.	Weight Kg/m
LFA 831 - K 325	6.11.040	LFA Acetal resin (Light brown)	82,5	4,8	8,7	1,00
LFA 831 - K 400	6.11.070		101,6			1,15
LFA 831 - K 450	6.11.080		114,3			1,24
LFA 831 - K 600	6.11.100		152,4			1,51
LFA 831 - K 750	6.11.110		190,5			1,76

- Standard shipping lengths = 80 pitches = 10 feet = 3,048 metres.
- These chains can be supplied either with pins in austenitic stainless steel, work hardened, highly wear resistant, or with pins in thermoplastic resin.

### 831 SP

#### Super Performance Acetal Resin

- Plates in self-lubricating very low friction acetal resin, dark grey-coloured.
- Pins in special chrome-nickel stainless steel, work hardened for high resistance.

Chain Ref.	Magris code	Material	Width L mm.	Thickness S mm.	Height h mm.	Weight Kg/m
SP 831 - K 325	6.21.040	SP Acetal resin (Dark grey)	82,5	4,8	8,7	1,00
SP 831 - K 400	6.21.070		101,6			1,15
SP 831 - K 450	6.21.080		114,3			1,24
SP 831 - K 600	6.21.100		152,4			1,51
SP 831 - K 750	6.21.110		190,5			1,76

- Standard shipping lengths = 80 pitches = 10 feet = 3,048 metres.
- These chains can be supplied either with pins in austenitic stainless steel, work hardened, highly wear resistant, or with pins in thermoplastic resin.



# Thermoplastic straight running chains - Double hinge

## 821 Series

Thermoplastic straight running chains - Double hinge

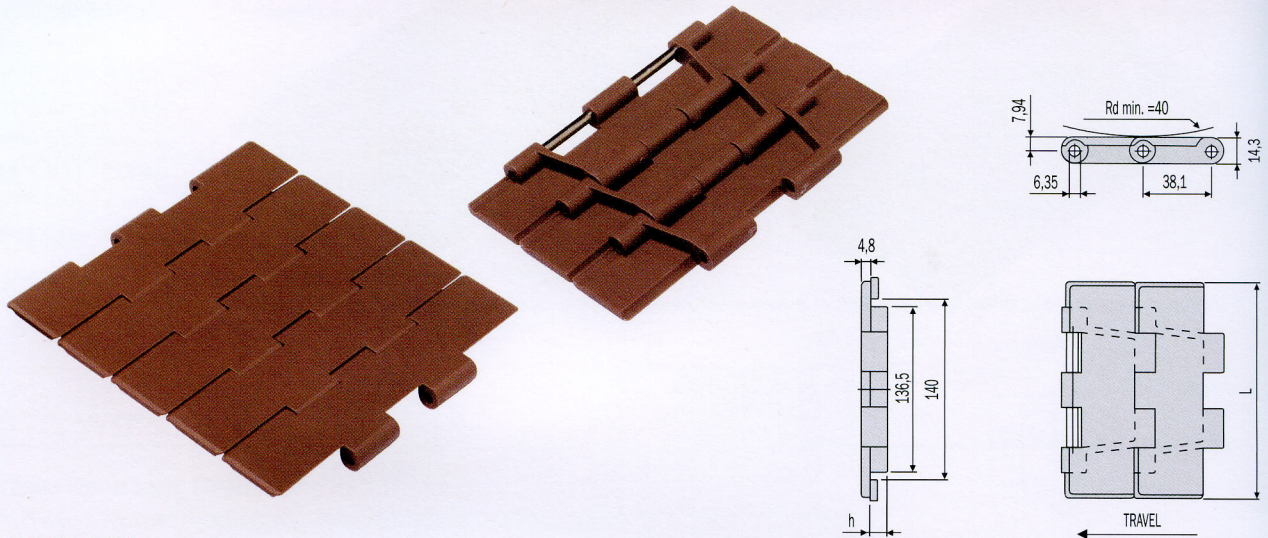

### 821 LFA

#### Low Friction Acetal Resin

- Plates in self-lubricating low friction acetal resin, light brown-coloured.
- Pins in special chrome-nickel stainless steel, work hardened for high resistance.

Chain Ref.	Magris code	Material	Width L mm.	Weight Kg/m
LFA 821 - K 750	6.14.110	LFA Acetal resin	190,5	2,50
LFA 821 - K 1000	6.14.120	(Light brown)	254,0	2,95
LFA 821 - K 1200	6.14.130		304,8	3,25

- Standard shipping lengths = 80 pitches = 10 feet = 3,048 metres.
- These chains can be supplied with pins in austenitic stainless steel, work hardened, highly wear resistant.

### 821 SP

#### Super Performance Acetal Resin

- Plates in self-lubricating very low friction acetal resin, dark grey-coloured.
- Pins in special chrome-nickel stainless steel, work hardened for high resistance.

Chain Ref.	Magris code	Material	Width L mm.	Weight Kg/m
SP 821 - K 750	6.24.110	SP Acetal resin	190,5	2,50
SP 821 - K 1000	6.24.120	(Dark grey)	254,0	2,95
SP 821 - K 1200	6.24.130		304,8	3,25

- Standard shipping lengths = 80 pitches = 10 feet = 3,048 metres.
- These chains can be supplied with pins in austenitic stainless steel, work hardened, highly wear resistant.

### 821 PPB

#### Chemical Resistant Reinforced Polypropylene

- Plates in chemical resistant reinforced polypropylene, white-coloured.
- Pins in chrome-nickel austenitic stainless steel (18% Chrome – 8% Nickel), work hardened for high resistance.

Chain Ref.	Magris code	Material	Width L mm.	Weight Kg/m
PPB 821 - K 750	6.44.110	PPB Reinforced	190,5	2,50
PPB 821 - K 1000	6.44.120	polypropylene	254,0	2,95
PPB 821 - K 1200	6.44.130	(White)	304,8	3,25

- Standard shipping lengths = 80 pitches = 10 feet = 3,048 metres.
- These chains can be supplied with pins in austenitic stainless steel, 316 series, work hardened, highly wear resistant.

# Thermoplastic sideflexing chains

## 880 Series

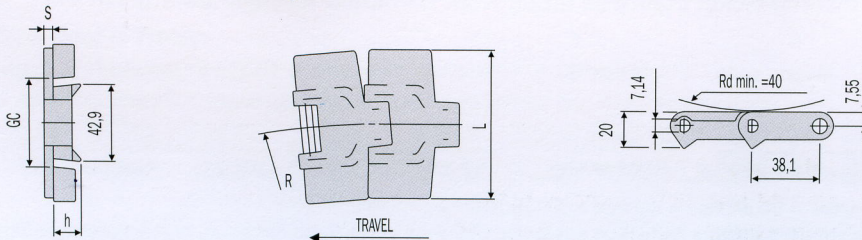
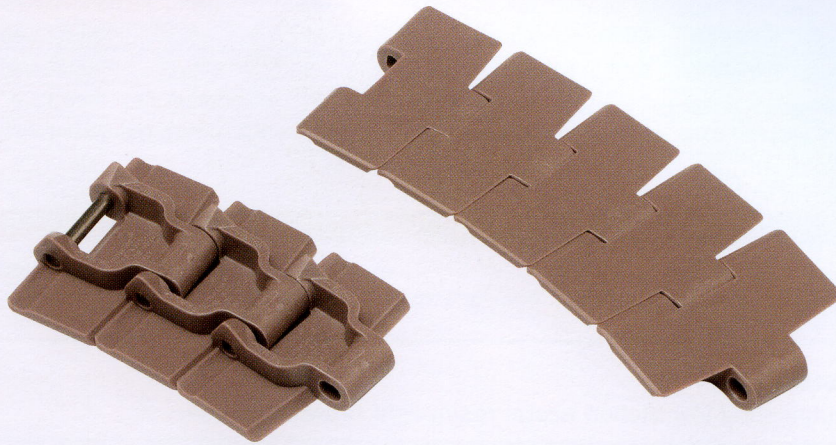

## 880 LFA

### Low Friction Acetal Resin

- Plates in self-lubricating low friction acetal resin, light brown-coloured.
- Pins in special chrome-nickel stainless steel, work hardened for high resistance.

Chain Ref.	Magris code	Material	Width L	Thickness S	Height h	Min.Radius R	GC Straight	GC Sidefl.	Weight
			mm.	mm.	mm.	mm.	mm.	mm.	Kg/m
LFA 880 - K 325	6.12.040	LFA Acetal resin (Light brown)	82,5	4	16	400	44,5	41,4	0,89
LFA 880 - K 350	6.12.060		88,9			400			0,91
LFA 880 - K 450	6.12.080		114,3			400			1,04
LFA 880 - K 750	6.12.110		190,5			400			1,40

- Standard shipping lengths = 80 pitches = 10 feet = 3,048 metres.

- These chains can be supplied either with pins in austenitic stainless steel, work hardened, highly wear resistant, or with pins in thermoplastic resin.

## 880 SP

### Super Performance Acetal Resin

- Plates in self-lubricating very low friction acetal resin, dark grey-coloured.
- Pins in special chrome-nickel stainless steel, work hardened for high resistance.

Chain Ref.	Magris code	Material	Width L	Thickness S	Height h	Min.Radius R	GC Straight	GC Sidefl.	Weight
			mm.	mm.	mm.	mm.	mm.	mm.	Kg/m
SP 880 - K 325	6.22.040	SP Acetal resin (Dark grey)	82,5	4	16	400	44,5	41,4	0,89
SP 880 - K 350	6.22.060		88,9			400			0,91
SP 880 - K 450	6.22.080		114,3			400			1,04
SP 880 - K 750	6.22.110		190,5			400			1,40

- Standard shipping lengths = 80 pitches = 10 feet = 3,048 metres.

- These chains can be supplied either with pins in austenitic stainless steel, work hardened, highly wear resistant, or with pins in thermoplastic resin.

## 880 WR

### Wear Resistant Resin

- Plates in thermoplastic wear resistant acetal resin, light grey-coloured.
- Pins in special chrome-nickel stainless steel, work hardened for high resistance.

Chain Ref.	Magris code	Material	Width L mm.	Thickness S mm.	Height h mm.	Min.Radius R mm.	GC Straight mm.	GC Sidefl. mm.	Weight Kg/m
WR 880 - K 325	6.52.040	WR Special acetal	82,5	4	16	400	44,5	41,4	0,89
WR 880 - K 450	6.52.080	resin (Light grey)	114,3	4	16	400	44,5	41,4	1,04

- Standard shipping lengths = 80 pitches = 10 feet = 3,048 metres.

- These chains can be supplied either with pins in austenitic stainless steel, work hardened, highly wear resistant, or with pins in thermoplastic resin.

## 879 Series

### 879 LFA

#### Low Friction Acetal Resin

- Plates in self-lubricating low friction acetal resin, light brown-coloured.
- Pins in special chrome-nickel stainless steel, work hardened for high resistance.

Chain Ref.	Magris code	Material	Width L mm.	Thickness S mm.	Height h mm.	Min.Radius R mm.	GC Straight mm.	GC Sidefl. mm.	Weight Kg/m
LFA 879 - K 325	6.13.040	LFA Acetal resin	82,5	4,8	15,2	400	44,5	41,4	0,93
LFA 879 - K 450	6.13.080	(Light brown)	114,3	4,8	15,2	400	44,5	41,4	1,10

- Standard shipping lengths = 80 pitches = 10 feet = 3,048 metres.

- These chains can be supplied either with pins in austenitic stainless steel, work hardened, highly wear resistant, or with pins in thermoplastic resin.

## 880 TAB Series

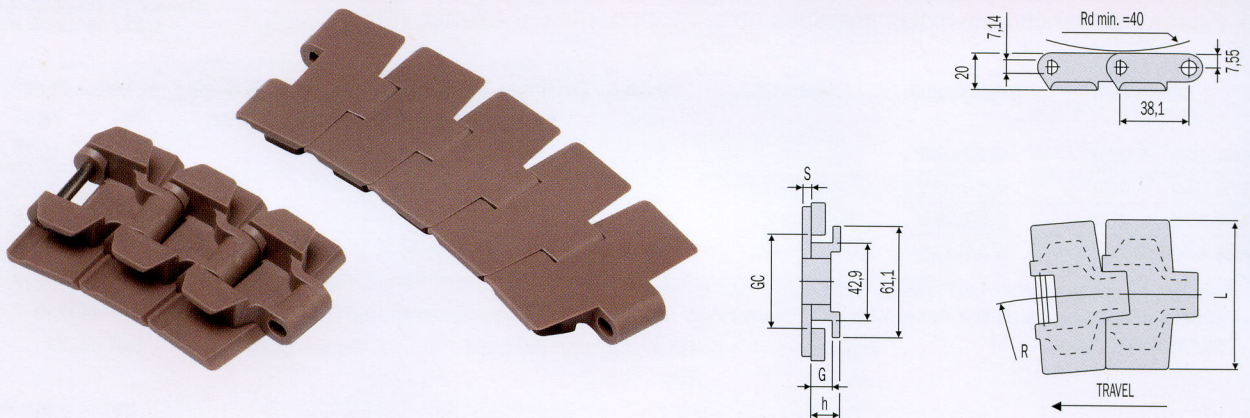

### 880 TAB D

#### Acetal Resin

- Plates in self-lubricating acetal resin, grey-coloured.
- Pins in special chrome-nickel stainless steel, work hardened for high resistance.

Chain Ref.	Magris code	Material	Width L mm.	Thickness S mm.	G mm.	Height h mm.	Min.Radius R mm.	GC Straight mm.	GC Sidefl. mm.	Weight Kg/m
D 880 TAB - K 325	6.02.041	D Acetal resin (Grey)	82,5	4	11,5	16	400	46	44,2	0,94
D 880 TAB - K 350	6.02.061		88,9							
D 880 TAB - K 450	6.02.081		114,3							
D 880 TAB - K 750	6.02.111		190,5							

- Standard shipping lengths = 80 pitches = 10 feet = 3,048 metres.

- The above-mentioned chains can also be produced in acetal resin, white-coloured.

- These chains can be supplied either with pins in austenitic stainless steel, work hardened, highly wear resistant, or with pins in thermoplastic resin.

## 880 TAB LFA

### Low Friction Acetal Resin

- Plates in self-lubricating low friction acetal resin, light brown-coloured.
- Pins in special chrome-nickel stainless steel, work hardened for high resistance.

Chain Ref.	Magris code	Material	Width L	Thickness S	G	Height h	Min.Radius R	GC Straight	GC Sidefl.	Weight
			mm.	mm.	mm.	mm.	mm.	mm.	mm.	Kg/m
LFA 880 TAB - K 250	6.12.021	LFA Acetal resin (Light brown)	63,5	4	11,5	16	400	46	44,2	0,80
LFA 880 TAB - K 325	6.12.041		82,5							0,94
LFA 880 TAB - K 343	6.12.043		87,0							0,99
LFA 880 TAB - K 350	6.12.061		88,9							1,01
LFA 880 TAB - K 450	6.12.081		114,3							1,08
LFA 880 TAB - K 600	6.12.101		152,4							1,28
LFA 880 TAB - K 750	6.12.111		190,5							1,48

- Standard shipping lengths = 80 pitches = 10 feet = 3,048 metres.

- These chains can be supplied either with pins in austenitic stainless steel, work hardened, highly wear resistant, or with pins in thermoplastic resin.

## 880 TAB SP

### Super Performance Acetal Resin

- Plates in self-lubricating very low friction acetal resin, dark grey-coloured.
- Pins in special chrome-nickel stainless steel, work hardened for high resistance.

Chain Ref.	Magris code	Material	Width L	Thickness S	G	Height h	Min.Radius R	GC Straight	GC Sidefl.	Weight
			mm.	mm.	mm.	mm.	mm.	mm.	mm.	Kg/m
SP 880 TAB - K 250	6.22.021	SP Acetal resin (Dark grey)	63,5	4	11,5	16	400	46	44,2	0,80
SP 880 TAB - K 325	6.22.041		82,5							0,94
SP 880 TAB - K 343	6.22.043		87,0							0,99
SP 880 TAB - K 350	6.22.061		88,9							1,01
SP 880 TAB - K 450	6.22.081		114,3							1,08
SP 880 TAB - K 600	6.22.101		152,4							1,28
SP 880 TAB - K 750	6.22.111		190,5							1,48

- Standard shipping lengths = 80 pitches = 10 feet = 3,048 metres.

- These chains can be supplied either with pins in austenitic stainless steel, work hardened, highly wear resistant, or with pins in thermoplastic resin.

## 880 TAB AS

### Antistatic Acetal Resin

- Plates in antistatic conductive acetal resin, black-coloured.
- Pins in special chrome-nickel stainless steel, work hardened for high resistance.

Chain Ref.	Magris code	Material	Width L	Thickness S	G	Height h	Min.Radius R	GC Straight	GC Sidefl.	Weight
			mm.	mm.	mm.	mm.	mm.	mm.	mm.	Kg/m
AS 880 TAB - K 325	6.32.041	AS Acetal resin (Black)	82,5	4	11,5	16	400	46	44,2	0,94
AS 880 TAB - K 450	6.32.081		114,3	4	11,5	16	400	46	44,2	1,08

- Standard shipping lengths = 80 pitches = 10 feet = 3,048 metres.

- These chains can be supplied either with pins in austenitic stainless steel, work hardened, highly wear resistant, or with pins in thermoplastic resin.

## 880 TAB WR

### Wear Resistant Resin

- Plates in thermoplastic wear resistant acetal resin, light grey-coloured.
- Pins in special chrome-nickel stainless steel, work hardened for high resistance.

Chain Ref.	Magris code	Material	Width L	Thickness S	G	Height h	Min.Radius R	GC Straight	GC Sidefl.	Weight
			mm.	mm.	mm.	mm.	mm.	mm.	mm.	Kg/m
<b>WR 880 TAB - K 325</b>	<b>6.52.041</b>	WR Special acetal	82,5	4	11,5	16	400	46	44,2	0,94
<b>WR 880 TAB - K 450</b>	<b>6.52.081</b>	resin (Light grey)	114,3	4	11,5	16	400	46	44,2	1,08

- Standard shipping lengths = 80 pitches = 10 feet = 3,048 metres.

- These chains can be supplied either with pins in austenitic stainless steel, work hardened, highly wear resistant, or with pins in thermoplastic resin.

## 879 TAB Series

### 879 TAB LFA

#### Low Friction Acetal Resin

- Plates in self-lubricating low friction acetal resin, light brown-coloured.
- Pins in special chrome-nickel stainless steel, work hardened for high resistance.

Chain Ref.	Magris code	Material	Width L	Thickness S	G	Height h	Min.Radius R	GC Straight	GC Sidefl.	Weight
			mm.	mm.	mm.	mm.	mm.	mm.	mm.	Kg/m
<b>LFA 879 TAB - K 325</b>	<b>6.13.041</b>	LFA Acetal resin	82,5	4,8	11	15,2	400	46	44,2	0,98
<b>LFA 879 TAB - K 450</b>	<b>6.13.081</b>	(Light brown)	114,3	4,8	11	15,2	400	46	44,2	1,14

- Standard shipping lengths = 80 pitches = 10 feet = 3,048 metres.

- These chains can be supplied either with pins in austenitic stainless steel, work hardened, highly wear resistant, or with pins in thermoplastic resin.

### 879 TAB SP

#### Super Performance Acetal Resin

- Plates in self-lubricating very low friction acetal resin, dark grey-coloured.
- Pins in special chrome-nickel stainless steel, work hardened for high resistance.

Chain Ref.	Magris code	Material	Width L	Thickness S	G	Height h	Min.Radius R	GC Straight	GC Sidefl.	Weight
			mm.	mm.	mm.	mm.	mm.	mm.	mm.	Kg/m
<b>SP 879 TAB - K 325</b>	<b>6.23.041</b>	SP Acetal resin	82,5	4,8	11	15,2	400	46	44,2	0,98
<b>SP 879 TAB - K 450</b>	<b>6.23.081</b>	(Dark grey)	114,3	4,8	11	15,2	400	46	44,2	1,14

- Standard shipping lengths = 80 pitches = 10 feet = 3,048 metres.

- These chains can be supplied either with pins in austenitic stainless steel, work hardened, highly wear resistant, or with pins in thermoplastic resin.

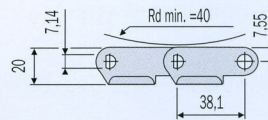
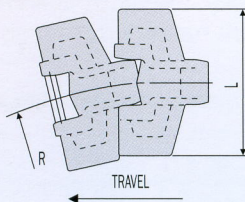
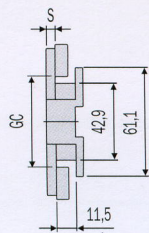
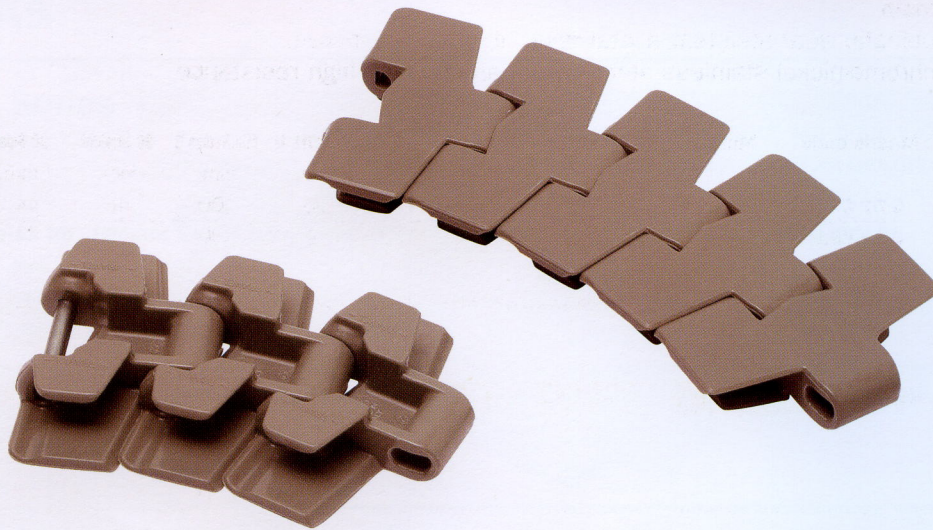

## 880 B0 LFA

### Low Friction Acetal Resin

- Plates in self-lubricating low friction acetal resin, light brown-coloured.
- Pins in special chrome-nickel stainless steel, work hardened for high resistance.

Chain Ref.	Magris code	Material	Width L	Thickness S	Min.Radius R	GC Straight	GC Sidefl.	Weight
			mm.	mm.	mm.	mm.	mm.	Kg/m
<b>LFA 880 B0 - K 325</b>	<b>6.19.040</b>	LFA Acetal resin	82,5	4	190	46	44,2	0,96
<b>LFA 880 B0 - K 450</b>	<b>6.19.080</b>	(Light brown)	114,3	4	190	46	44,2	1,11

- Standard shipping lengths = 80 pitches = 10 feet = 3,048 metres.

- These chains can be supplied either with pins in austenitic stainless steel, work hardened, highly wear resistant, or with pins in thermoplastic resin.

## 880 B0 WR

### Wear Resistant Resin

- Plates in thermoplastic wear resistant acetal resin, light grey-coloured.
- Pins in special chrome-nickel stainless steel, work hardened for high resistance.

Chain Ref.	Magris code	Material	Width L	Thickness S	Min.Radius R	GC Straight	GC Sidefl.	Weight
			mm.	mm.	mm.	mm.	mm.	Kg/m
<b>WR 880 B0 - K 325</b>	<b>6.59.040</b>	WR Special acetal	82,5	4	190	46	44,2	0,96
<b>WR 880 B0 - K 450</b>	<b>6.59.080</b>	resin (Light grey)	114,3	4	190	46	44,2	1,11

- Standard shipping lengths = 80 pitches = 10 feet = 3,048 metres.

- These chains can be supplied either with pins in austenitic stainless steel, work hardened, highly wear resistant, or with pins in thermoplastic resin.

## 879 B0 Series

### 879 B0 LFA

#### Low Friction Acetal Resin

- Plates in self-lubricating low friction acetal resin, light brown-coloured.
- Pins in special chrome-nickel stainless steel, work hardened for high resistance.

Chain Ref.	Magris code	Material	Width L mm.	Thickness S mm.	Min.Radius R mm.	GC Straight mm.	GC Sidefl. mm.	Weight Kg/m
LFA 879 B0 - K 325	6.17.040	LFA Acetal resin	82,5	4,8	190	46	44,2	1,08
LFA 879 B0 - K 450	6.17.080	(Light brown)	114,3	4,8	190	46	44,2	1,23

- Standard shipping lengths = 80 pitches = 10 feet = 3,048 metres.

- These chains can be supplied either with pins in austenitic stainless steel, work hardened, highly wear resistant, or with pins in thermoplastic resin.

### 879 B0 WR

#### Wear Resistant Resin

- Plates in thermoplastic wear resistant special resin, light grey-coloured.
- Pins in special chrome-nickel stainless steel, work hardened for high resistance.

Chain Ref.	Magris code	Material	Width L mm.	Thickness S mm.	Min.Radius R mm.	GC Straight mm.	GC Sidefl. mm.	Weight Kg/m
WR 879 B0 - K 325	6.57.040	WR Special acetal	82,5	4,8	190	46	44,2	1,08
WR 879 B0 - K 450	6.57.080	resin (Light grey)	114,3	4,8	190	46	44,2	1,23

- Standard shipping lengths = 80 pitches = 10 feet = 3,048 metres.

- These chains can be supplied either with pins in austenitic stainless steel, work hardened, highly wear resistant, or with pins in thermoplastic resin.

## 878 B0 Series

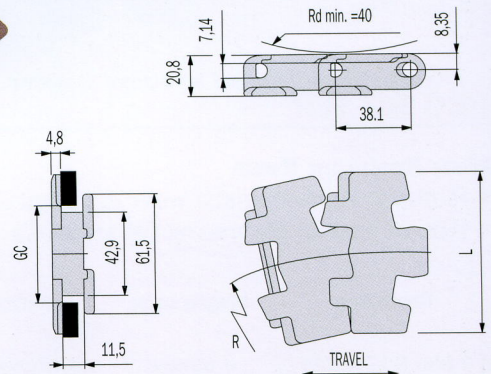
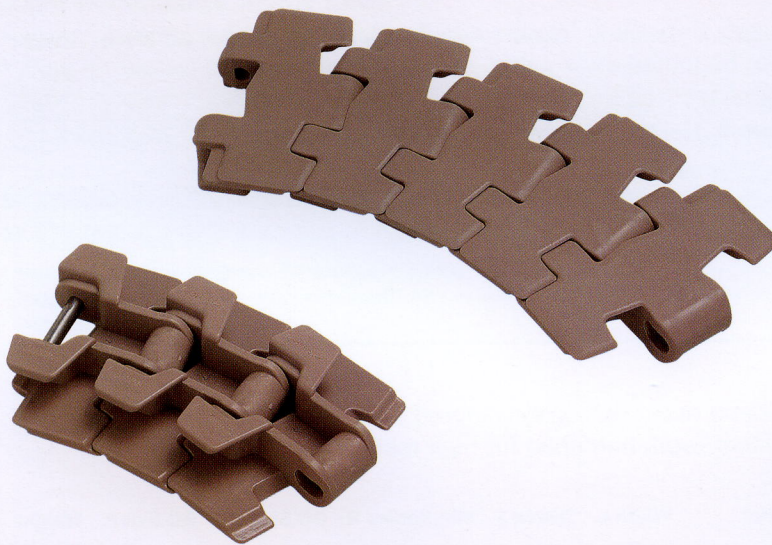

### 878 B0 LFA

#### Low friction Acetal Resin

- Plates in self-lubricating low friction acetal resin, light brown-coloured.
- Pins in special chrome-nickel stainless steel, work hardened for high resistance.

Chain Ref.	Magris code	Material	Width L mm.	Min.Radius R mm.	GC Straight mm.	GC Sidefl. mm.	Weight Kg/m
LFA 878 B0 - K 325	6.17.041	LFA Acetal resin	82,5	190	46	44,2	1,08
LFA 878 B0 - K 450	6.17.081	(Light brown)	114,3	190	46	44,2	1,20

- Standard shipping lengths = 80 pitches = 10 feet = 3,048 metres.

- These chains can be supplied either with pins in austenitic stainless steel, work hardened, highly wear resistant, or with pins in thermoplastic resin.

# Thermoplastic sideflexing chains on magnetic tracks

## 880 M Series

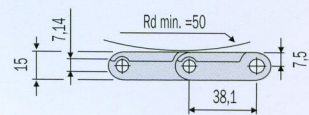
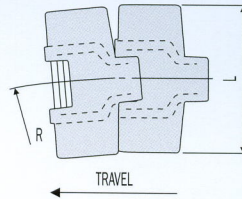
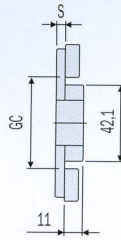
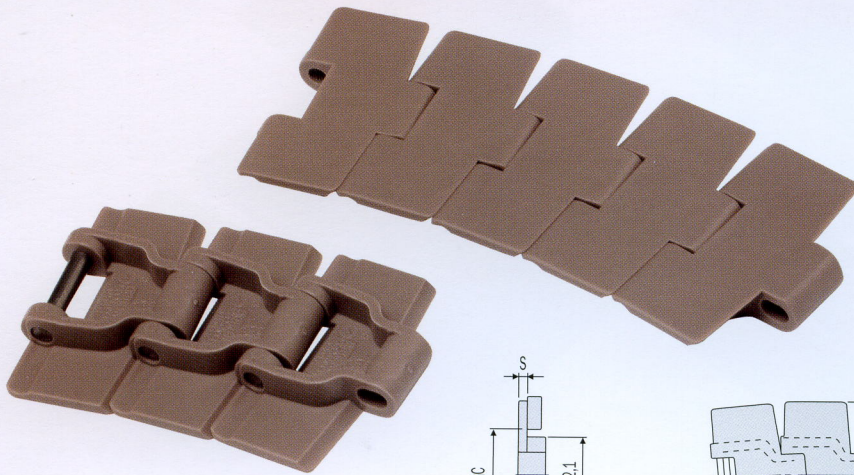

### 880 M LFA

#### Low Friction Acetal Resin

- Plates in self-lubricating low friction acetal resin, light brown-coloured.
- Pins in special stainless steel, 400 series, work hardened, magnetic, highly wear resistant.

Chain Ref.	Magris code	Material	Width L mm.	Thickness S mm.	Min.Radius R mm.	GC Straight mm.	GC Sidefl. mm.	Weight Kg/m
LFA 880 M - K 325	6.18.040	LFA Acetal resin (Light brown)	82,5	4	457	44	44	1,03
LFA 880 M - K 330	6.18.042		83,8					1,03
LFA 880 M - K 450	6.18.080		114,3					1,16

- Standard shipping lengths = 80 pitches = 10 feet = 3,048 metres.

### 880 M SP

#### Super Performance Acetal Resin

- Plates in self-lubricating very low friction acetal resin, dark grey-coloured.
- Pins in special stainless steel, 400 series, work hardened, magnetic, highly wear resistant.

Chain Ref.	Magris code	Material	Width L mm.	Thickness S mm.	Min.Radius R mm.	GC Straight mm.	GC Sidefl. mm.	Weight Kg/m
SP 880 M - K 325	6.28.040	SP Acetal resin (Dark grey)	82,5	4	457	44	44	1,03
SP 880 M - K 450	6.28.080		114,3	4				457

- Standard shipping lengths = 80 pitches = 10 feet = 3,048 metres.

## 879 M Series

### 879 M LFA

#### Low Friction Acetal Resin

- Plates in self-lubricating low friction acetal resin, light brown-coloured.
- Pins in special stainless steel, 400 series, work hardened, magnetic, highly wear resistant.

Chain Ref.	Magris code	Material	Width L mm.	Thickness S mm.	Min.Radius R mm.	GC Straight mm.	GC Sidefl. mm.	Weight Kg/m
LFA 879 M - K 325	6.16.040	LFA Acetal resin (Light brown)	82,5	4,8	457	44	44	1,08

- Standard shipping lengths = 80 pitches = 10 feet = 3,048 metres.



# Thermoplastic sideflexing chains

## 882 Series

Thermoplastic sideflexing chains

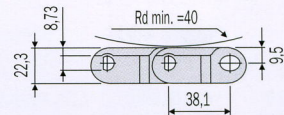
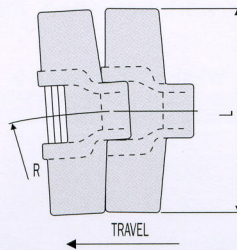
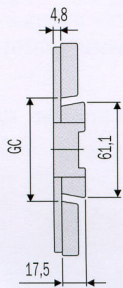
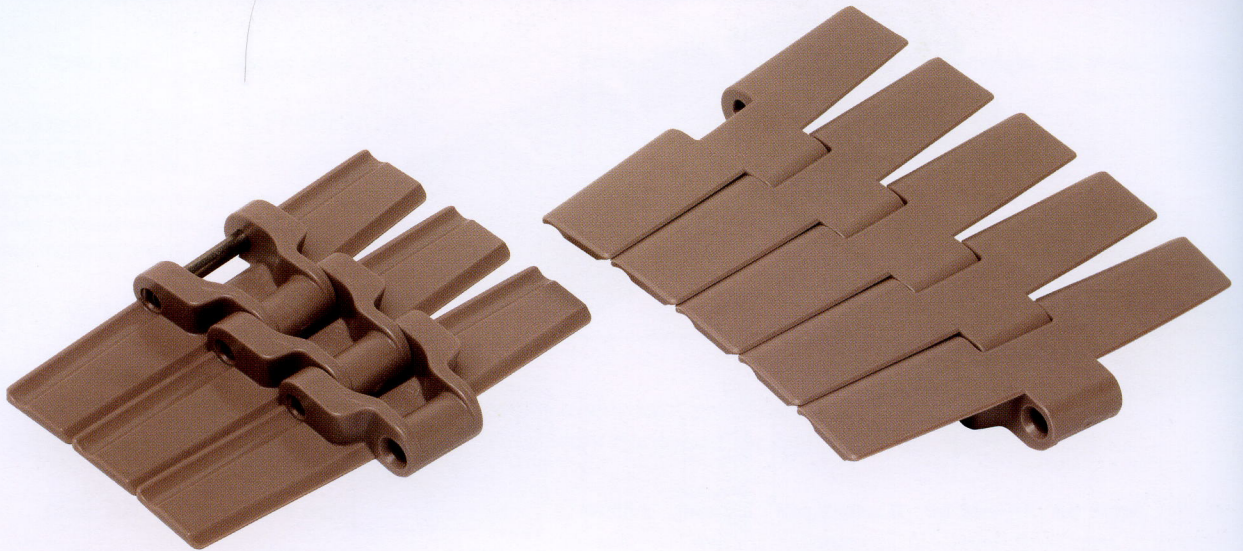

## 882 LFA

### Low Friction Acetal Resin

- Plates in self-lubricating low friction acetal resin, light brown-coloured.
- Pins in special chrome-nickel stainless steel, work hardened for high resistance.

Chain Ref.	Magris code	Material	Width L mm.	Min.Radius R mm.	GC Straight mm.	GC Sidefl. mm.	Weight Kg/m
LFA 882 - K 450	6.15.080	LFA Acetal resin (Light brown)	114,3	610	61,9	58	1,94
LFA 882 - K 750	6.15.110		190,5				2,38
LFA 882 - K 1000	6.15.120		254,0				2,83
LFA 882 - K 1200	6.15.130		304,8				2,75

- Standard shipping lengths = 80 pitches = 10 feet = 3,048 metres.

- These chains can be supplied either with pins in austenitic stainless steel, work hardened, highly wear resistant, or with pins in thermoplastic resin.

# 882 TAB Series

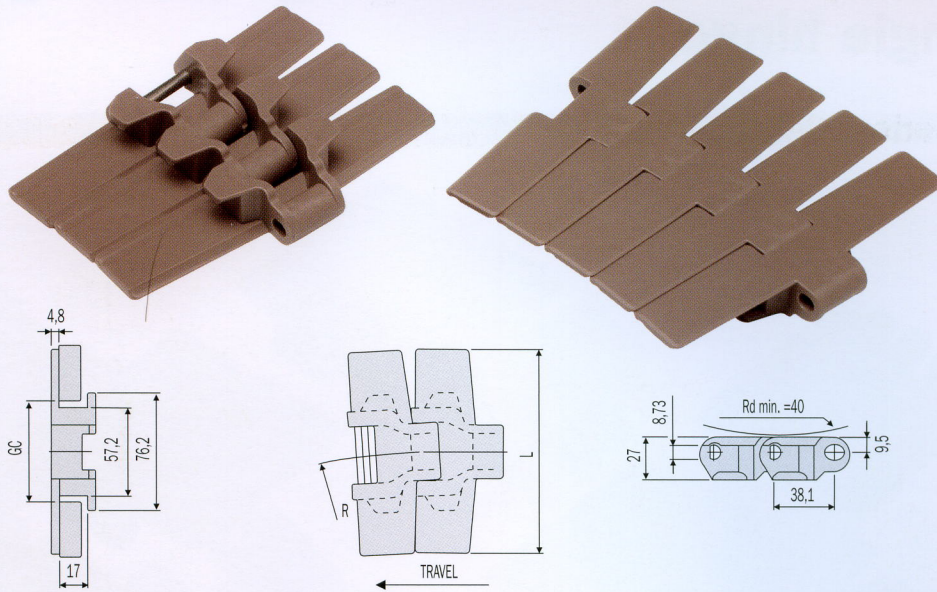

Thermoplastic sideflexing chains

## 882 TAB LFA

### Low Friction Acetal Resin

- Plates in self-lubricating low friction acetal resin, light brown-coloured.
- Pins in special chrome-nickel stainless steel, work hardened for high resistance.

Chain Ref.	Magris code	Material	Width L mm.	Min.Radius R mm.	GC Straight mm.	GC Sidefl. mm.	Weight Kg/m
LFA 882 TAB - K 450	6.15.081	LFA Acetal resin (Light brown)	114,3	610	60	58	1,98
LFA 882 TAB - K 750	6.15.111		190,5				2,43
LFA 882 TAB - K 1000	6.15.121		254,0				2,87
LFA 882 TAB - K 1200	6.15.131		304,8				3,41

- Standard shipping lengths = 80 pitches = 10 feet = 3,048 metres.

- These chains can be supplied either with pins in austenitic stainless steel, work hardened, highly wear resistant, or with pins in thermoplastic resin.

## 882 TAB SP

### Super Performance Acetal Resin

- Plates in self-lubricating very low friction acetal resin, dark grey-coloured.
- Pins in special chrome-nickel stainless steel, work hardened for high resistance.

Chain Ref.	Magris code	Material	Width L mm.	Min.Radius R mm.	GC Straight mm.	GC Sidefl. mm.	Weight Kg/m
SP 882 TAB - K 450	6.25.081	SP Acetal resin (Dark grey)	114,3	610	60	58	1,98
SP 882 TAB - K 750	6.25.111		190,5				2,43
SP 882 TAB - K 1000	6.25.121		254,0				2,87
SP 882 TAB - K 1200	6.25.131		304,8				3,41

- Standard shipping lengths = 80 pitches = 10 feet = 3,048 metres.

- These chains can be supplied either with pins in austenitic stainless steel, work hardened, highly wear resistant, or with pins in thermoplastic resin.

## 882 TAB PPB

### Chemical Resistant Reinforced Polypropylene

- Plates in chemical resistant reinforced polypropylene, white-coloured.
- Pins in chrome-nickel austenitic stainless steel (18% Chrome – 8% Nickel), work hardened for high resistance.

Chain Ref.	Magris code	Material	Width L mm.	Min.Radius R mm.	GC Straight mm.	GC Sidefl. mm.	Weight Kg/m
PPB 882 TAB - K 750*	6.45.111	PPB Reinforced polypropylene (White)	190,5	610	60	58	2,43
PPB 882 TAB - K 1000*	6.45.121		254,0				2,87
PPB 882 TAB - K 1200*	6.45.131		304,8				3,41

\*Size produced only upon request. Delivery conditions and terms to be agreed.

- Standard shipping lengths = 80 pitches = 10 feet = 3,048 metres.

- These chains can be supplied either with pins in austenitic stainless steel, work hardened, highly wear resistant, or with pins in thermoplastic resin.

# Vacuum thermoplastic straight running chains - Single hinge

820 Series **Vacuum**

Vacuum thermoplastic straight running chains - Single hinge

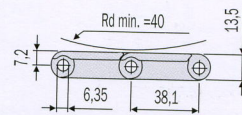
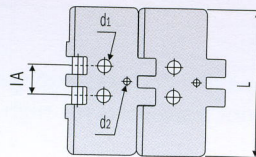
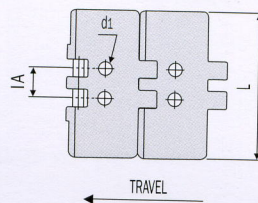
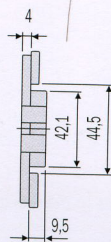
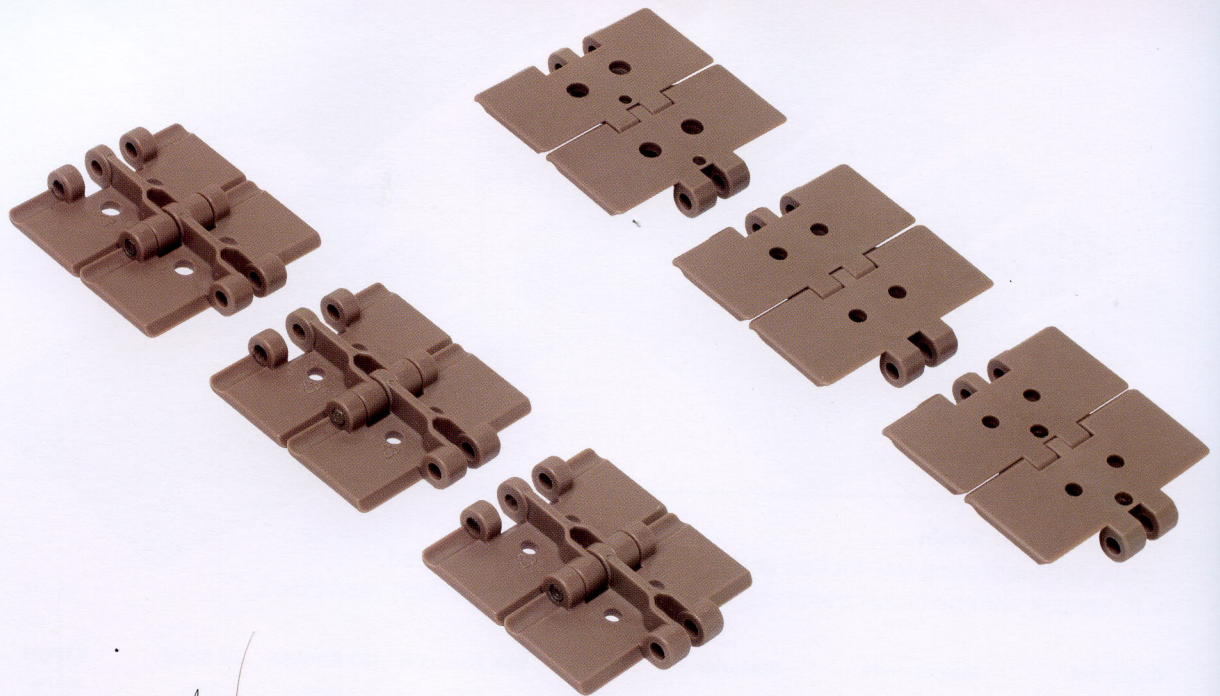

## 820 Vacuum LFA

### Low Friction Acetal Resin

- Plates in self-lubricating low friction acetal resin, light brown-coloured, with 2 or 3 bores per link.
- Pins in special chrome-nickel stainless steel, work hardened for high resistance.

Chain Ref.	Magris code	Material	Width L mm.	Ø Bore d1 mm.	Ø Bore d2 mm.	IA* mm.	Weight Kg/m
<b>B2 Two bores</b>							
LFA 820 - K 325 B 2	6.10.040.2	LFA Acetal resin (Light brown)	82,5	6,5	-	19	0,83
LFA 820 - K 350 B 2	6.10.060.2		88,9	4,0	-	45	0,87
LFA 820 - K 450 B 2 H30	6.10.080.2a		114,3	8,0	-	30	1,03
LFA 820 - K 450 B 2 H50	6.10.080.2b		114,3	8,0	-	50	1,03
<b>B3 Three bores</b>							
LFA 820 - K 325 B 3	6.10.040.3		82,5	7,9	4,4	20	0,83

\*IA = Distance between centres.

- Standard shipping lengths = 80 pitches = 10 feet = 3,048 metres.

- These chains can be supplied either with pins in austenitic stainless steel, work hardened, highly wear resistant, or with pins in thermoplastic resin.

# Vacuum thermoplastic sideflexing chains

## 880 TAB Series Vacuum

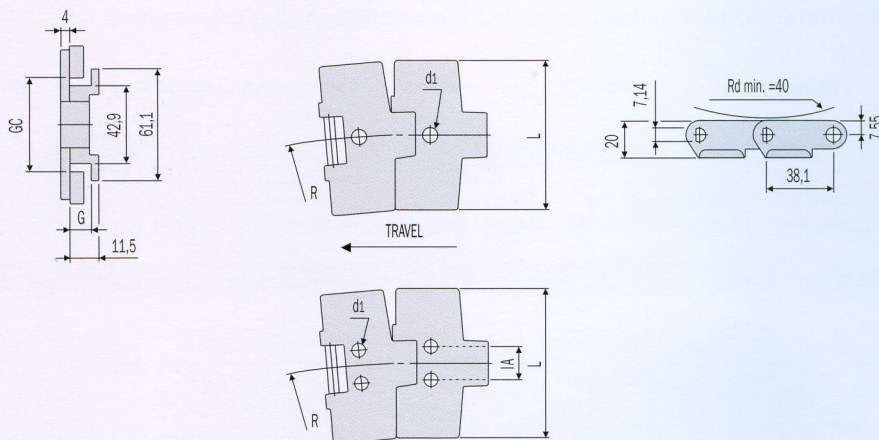
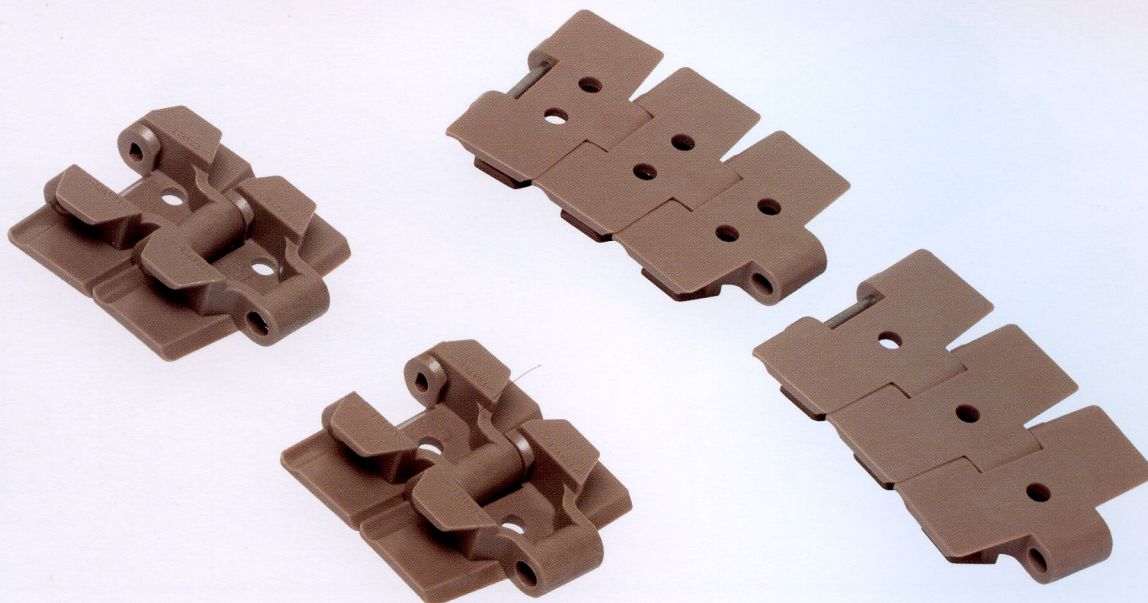

## 880 TAB Vacuum LFA

### Low Friction Acetal Resin

- Plates in self-lubricating low friction acetal resin, light brown-coloured, with 1 or 2 bores per link.
- Pins in special chrome-nickel stainless steel, work hardened for high resistance.

Chain Ref.	Magris code	Material	Width L mm.	Ø Bore d1 mm.	IA* mm.	Min. Radius R mm.	GC Straight mm.	GC Sidefl. mm.	Weight Kg/m
<b>B1 One bore</b>									
LFA 880 TAB - K 325 B 1...	6.12.041.1...	LFA Acetal resin (Light brown)	82,5	5/6/6,5/ 8/9,5/10	-	457	46	44,2	0,94
<b>B2 Two bores</b>									
LFA 880 TAB - K 325 B 2...	6.12.041.2a		82,5	6	24	457			0,94
	6.12.041.2b		82,5	8	20	457	46	44,2	0,94
LFA 880 TAB - K 450 B 2...	6.12.081.2a		114,3	6	24	610			1,08

\*IA = Distance between centres.

- Standard shipping lengths = 80 pitches = 10 feet = 3,048 metres.

- These chains can be supplied either with pins in austenitic stainless steel, work hardened, highly wear resistant, or with pins in thermoplastic resin.

# Thermoplastic sideflexing chains

Thermoplastic sideflexing chains

## 780 TAB Series

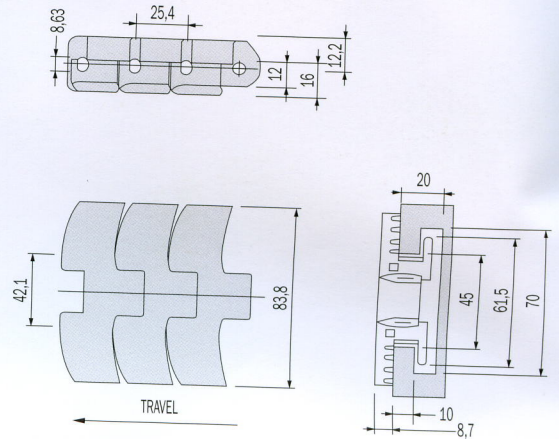
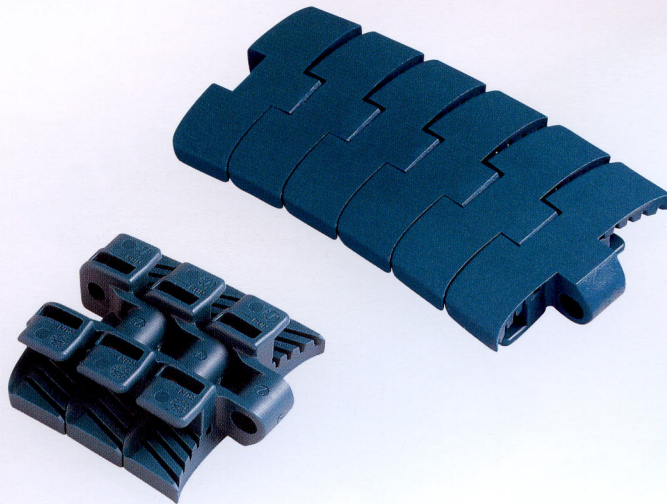

### LFA 780 TAB

#### Low Friction Acetal Resin

- Plates in self-lubricating low friction acetal resin, green-blue coloured.
- Pins in special chrome-nickel stainless steel, work hardened for high resistance.

Chain Ref.	Magris code	Material	Width L	Thickness S	Backflex Radius	Min.Radius R	Weight
			mm.	mm.	mm.	mm.	Kg/m
LFA 780 TAB - K 330	9.12.042	LFA Acetal r. (Green-blue)	83,8	8,7	130	500	1,93

- Standard shipping lengths = 120 pitches = 10 feet = 3,048 metres.

- These chains can be supplied with pins in austenitic stainless steel, work hardened, highly wear resistant.

## 790 TAB Series

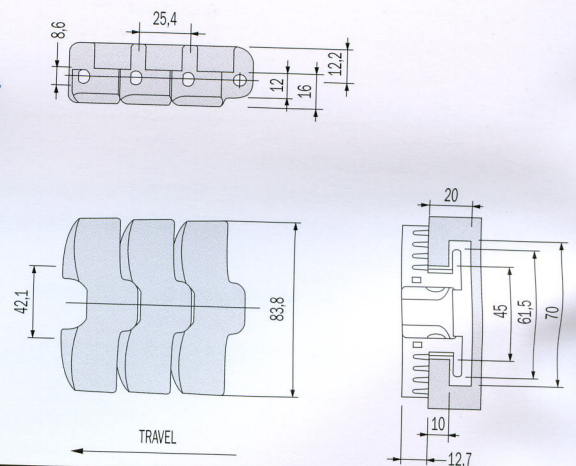
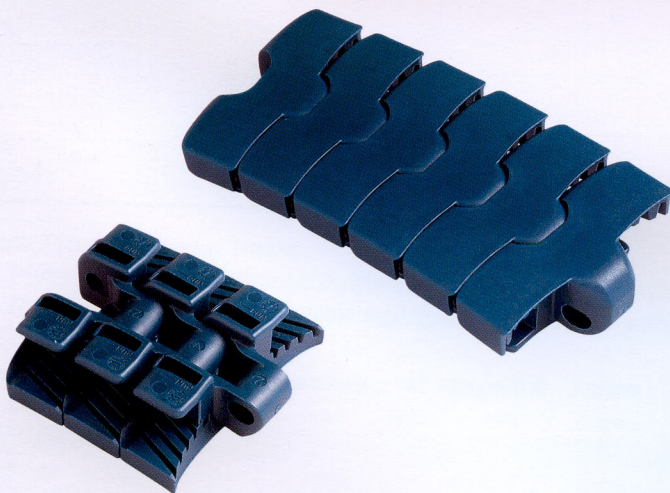

### LFA 790 TAB

#### Low Friction Acetal Resin

- Plates in self-lubricating low friction acetal resin, green-blue coloured.
- Pins in special chrome-nickel stainless steel, work hardened for high resistance.

Chain Ref.	Magris code	Material	Width L	Thickness S	Backflex Radius	Min.Radius R	Weight
			mm.	mm.	mm.	mm.	Kg/m
LFA 790 TAB - K 330	9.15.042	LFA Acetal r. (Green-blue)	83,8	12,7	130	500	2,13

- Standard shipping lengths = 120 pitches = 10 feet = 3,048 metres.

- These chains can be supplied with pins in austenitic stainless steel, work hardened, highly wear resistant.

# Straight running chains with thermoplastic Top Plates

## 843 Series

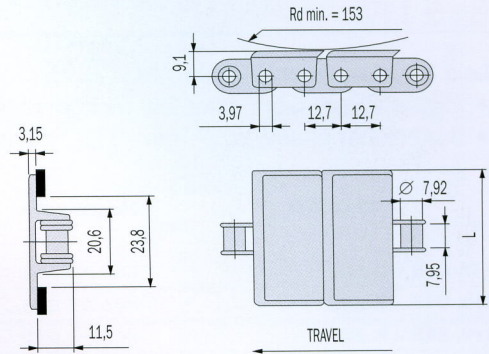
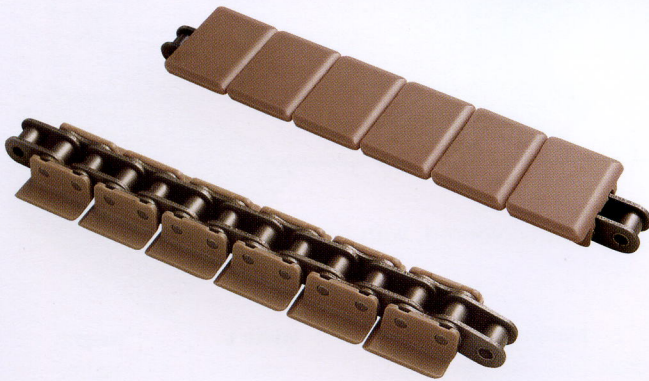

## 843 LFA

### Low Friction Acetal Resin

- Plates in self-lubricating low friction acetal resin, light brown-coloured, with base roller chain.
- Base roller chain, 12,7 mm - 1/2" pitch.

Chain Ref.	Magris code	Material		Width L mm.	Weight Kg/m
		Base chain	Top plate		
LFA 843 - K 138	843.AC.138	Steel	LFA Acetal resin (Light brown)	34,9	0,83
LFA 843 - K 144*	843.AC.144			36,5	0,84
LFA 843 - K 200	843.AC.010			50,8	0,89
LFA 843 - K 275*	843.AC.200			70,0	0,92
LFA 843 - K 325*	843.AC.040			82,5	1,03
LFA 843 SS - K 138	843.AS.138	Stainless Steel	LFA Acetal resin (Light brown)	34,9	0,83
LFA 843 SS - K 144*	843.AS.144			36,5	0,84
LFA 843 SS - K 200	843.AS.010			50,8	0,89
LFA 843 SS - K 275*	843.AS.200			70,0	0,92
LFA 843 SS - K 325	843.AS.040			82,5	1,03

\*Size produced only upon request. Delivery conditions and terms to be agreed.  
 - Standard shipping lengths = 240 pitches = 10 feet = 3,048 metres.

## 845 Series

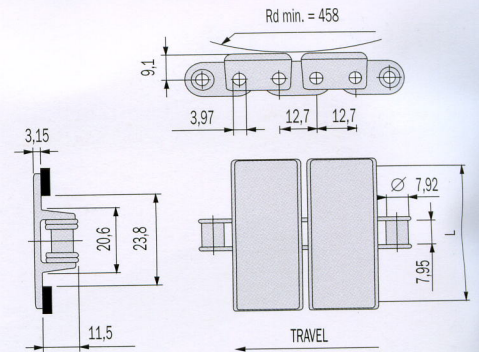
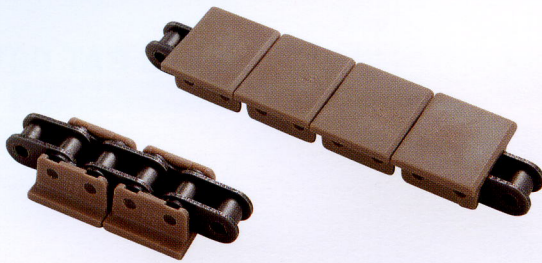

### 845 LFA

#### Low Friction Acetal Resin

- Plates in self-lubricating low friction acetal resin, light brown-coloured, with base roller chain.
- Base roller chain, 12,7 mm - 1/2" pitch.

Chain Ref.	Magris code	Material		Width L mm.	Weight Kg/m
		Base chain	Top plate		
LFA 845 - K 118*	845.AC.118	Steel	LFA Acetal resin (Light brown)	28,6	0,85
LFA 845 - K 138	845.AC.138			34,9	0,89
LFA 845 - K 200*	845.AC.010			50,8	0,99
LFA 845 SS - K 118*	845.AS.118	Stainless Steel	LFA Acetal resin (Light brown)	28,6	0,85
LFA 845 SS - K 138*	845.AS.138			34,9	0,89
LFA 845 SS - K 200*	845.AS.010			50,8	0,99

\*Size produced only upon request. Delivery conditions and terms to be agreed.  
- Standard shipping lengths = 240 pitches = 10 feet = 3,048 metres.

## 863 Series

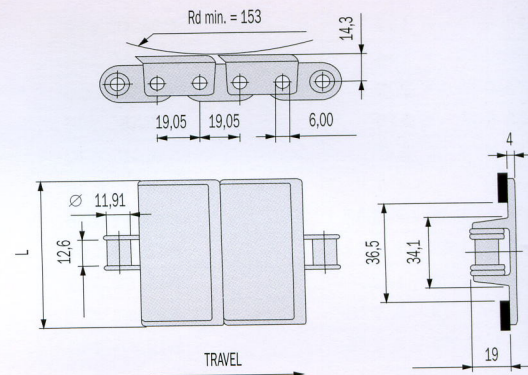
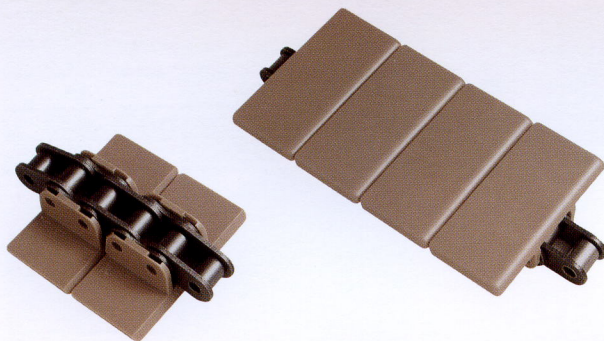

### 863 LFA

#### Low Friction Acetal Resin

- Plates in self-lubricating low friction acetal resin, light brown-coloured, with base roller chain.
- Base roller chain, 19,05 mm - 3/4" pitch.

Chain Ref.	Magris code	Material		Width L mm.	Weight Kg/m
		Base chain	Top plate		
LFA 863 - K 175*	863.AC.300	Steel	LFA Acetal resin (Light brown)	44,5	1,9
LFA 863 - K 250	863.AC.020			63,5	2,0
LFA 863 - K 325	863.AC.040			82,5	2,1
LFA 863 - K 450	863.AC.080			114,3	2,3
LFA 863 - K 600*	863.AC.100			152,4	2,5
LFA 863 - K 750	863.AC.110			190,5	2,7
LFA 863 SS - K 175*	863.AS.300	Stainless Steel	LFA Acetal resin (Light brown)	44,5	1,9
LFA 863 SS - K 250	863.AS.020			63,5	2,0
LFA 863 SS - K 325	863.AS.040			82,5	2,1
LFA 863 SS - K 450	863.AS.080			114,3	2,3
LFA 863 SS - K 600*	863.AS.100			152,4	2,5
LFA 863 SS - K 750	863.AS.110			190,5	2,7

\*Size produced only upon request. Delivery conditions and terms to be agreed.  
- Standard shipping lengths = 160 pitches = 10 feet = 3,048 metres.

## 963 Series

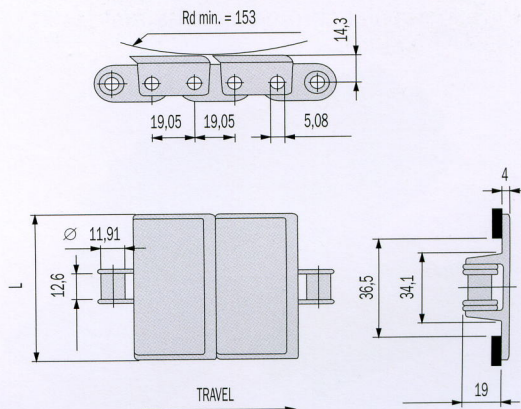
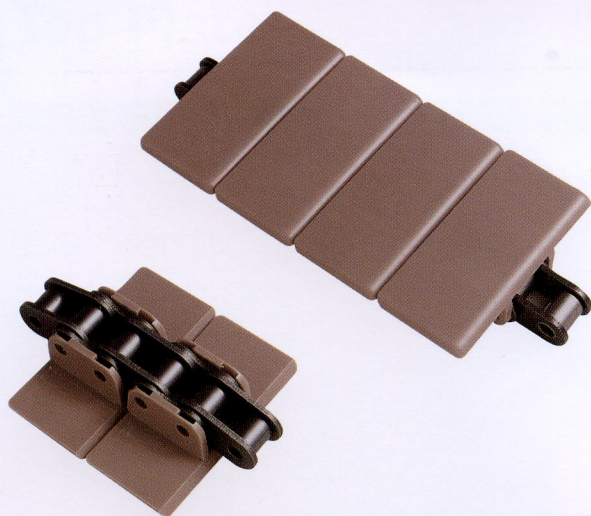

### 963 LFA

#### Low Friction Acetal Resin

- Plates in self-lubricating low friction acetal resin, light brown-coloured, with base roller chain.
- Base roller chain, 19,05 mm - 3/4" pitch.

Chain Ref.	Magris code	Material		Width L mm.	Weight Kg/m
		Base chain	Top plate		
LFA 963 - K 325*	963.AC.040	Steel	LFA Acetal resin (Light brown)	82,5	2,10
LFA 963 - K 450*	963.AC.080			114,3	2,23
LFA 963 - K 600*	963.AC.100			152,4	2,53
LFA 963 - K 750*	963.AC.110			190,5	2,68
LFA 963 SS - K 325*	963.AS.040	Stainless Steel	LFA Acetal resin (Light brown)	82,5	2,10
LFA 963 SS - K 450*	963.AS.080			114,3	2,23
LFA 963 SS - K 600*	963.AS.100			152,4	2,53
LFA 963 SS - K 750*	963.AS.110			190,5	2,68

\*Size produced only upon request. Delivery conditions and terms to be agreed.  
 - Standard shipping lengths = 160 pitches = 10 feet = 3,048 metres.



# "1843" Sideflexing chains with thermoplastic Top Plates

## 1843 Series

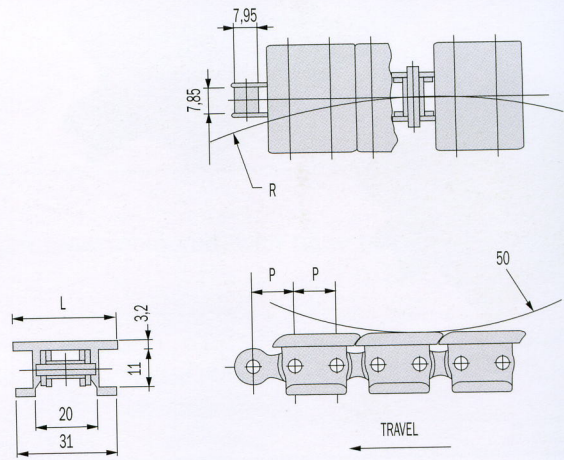
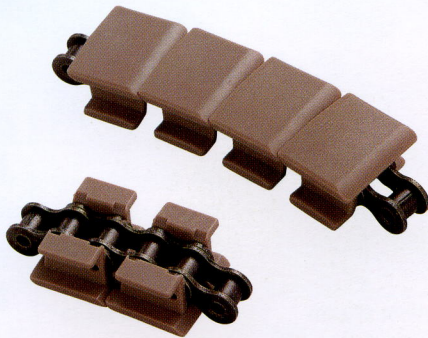

### 1843 LFA

#### Low Friction Acetal Resin

- Plates in self-lubricating low friction acetal resin, light brown-coloured, with base roller chain.
- Base roller chain, 12,7 mm - 1/2" pitch.

Chain Ref.	Magris code	Material		Width L mm.	Pitch P mm.	Min. Radius R mm.	Weight Kg/m
		Base chain	Top plate				
LFA 1843 TAB - K 125	1843.AC.280	Steel	LFA Acetal resin (Light brown)	31,80	12,7	254	0,74
LFA 1843 TAB - K 200	1843.AC.010	Steel		50,80			0,89
LFA 1843 TAB SS - K 125	1843.AS.280	Stainless Steel	LFA Acetal resin (Light brown)	31,80	12,7	254	0,74
LFA 1843 TAB SS - K 200	1843.AS.010	Stainless Steel		50,80			0,89

- Standard shipping lengths = 240 pitches = 10 feet = 3,048 metres.

# “1873” Sideflexing chains with thermoplastic Top Plates

## 1873 Series

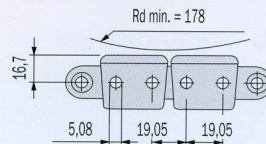
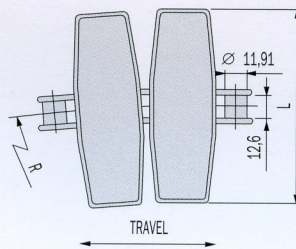
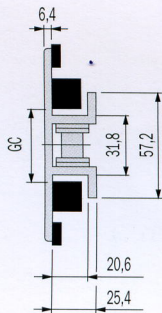
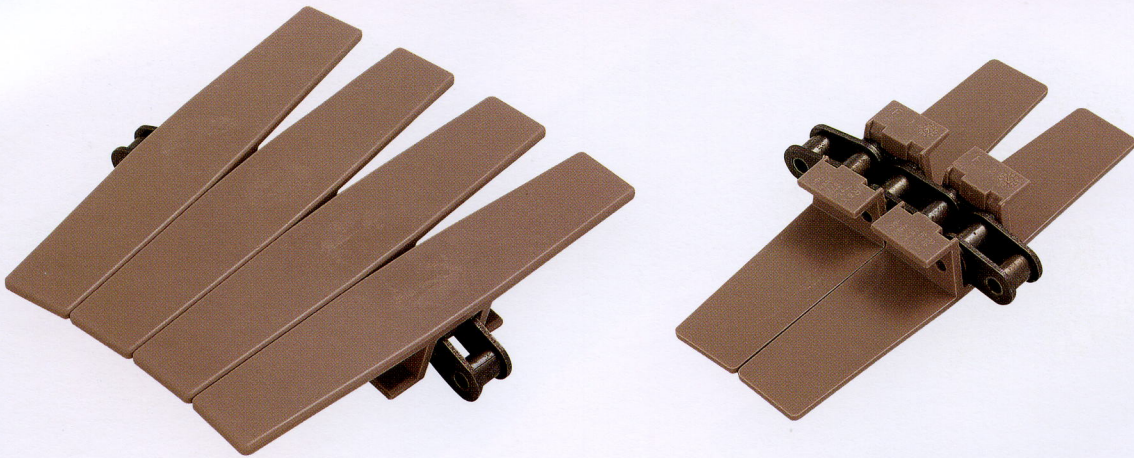

## 1873 LFA

### Low Friction Acetal Resin

- Plates in self-lubricating low friction acetal resin, light brown-coloured, with base roller chain.
- Base roller chain, 19,05 mm - 3/4" pitch.

Chain Ref.	Magris code	Material		Width L mm.	Min. Radius R mm.	GC Straight mm.	GC Curve mm.	Weight Kg/m
		Base chain	Top plate					
LFA 1873 TAB - K 325	1873.AC.041	Steel	LFA Acetal resin (Light brown)	82,5	356	33,3	34,6	2,1
LFA 1873 TAB - K 450	1873.AC.081			114,3	356			2,3
LFA 1873 TAB - K 600	1873.AC.101			152,4	457			2,4
LFA 1873 TAB - K 750	1873.AC.111			190,5	457			2,6
LFA 1873 TAB - K 1000	1873.AC.121			254,0	457			2,8
LFA 1873 TAB - K 1200	1873.AC.131			304,8	610			3,0
LFA 1873 TAB SS - K 325	1873.AS.041	Stainless Steel	LFA Acetal resin (Light brown)	82,5	356	33,3	34,6	2,1
LFA 1873 TAB SS - K 450	1873.AS.081			114,3	356			2,3
LFA 1873 TAB SS - K 600	1873.AS.101			152,4	457			2,4
LFA 1873 TAB SS - K 750	1873.AS.111			190,5	457			2,6
LFA 1873 TAB SS - K 1000	1873.AS.121			254,0	457			2,8
LFA 1873 TAB SS - K 1200	1873.AS.131			304,8	610			3,0

- Standard shipping lengths = 160 pitches = 10 feet = 3,048 metres.

# Thermoplastic straight running chains with rubber inserts - Single hinge

## HFL 820 Series

Thermoplastic straight running chains with rubber inserts - Single hinge

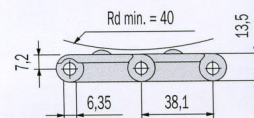
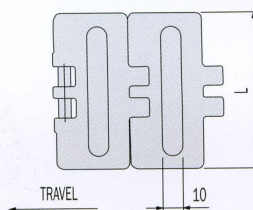
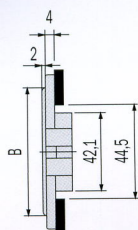
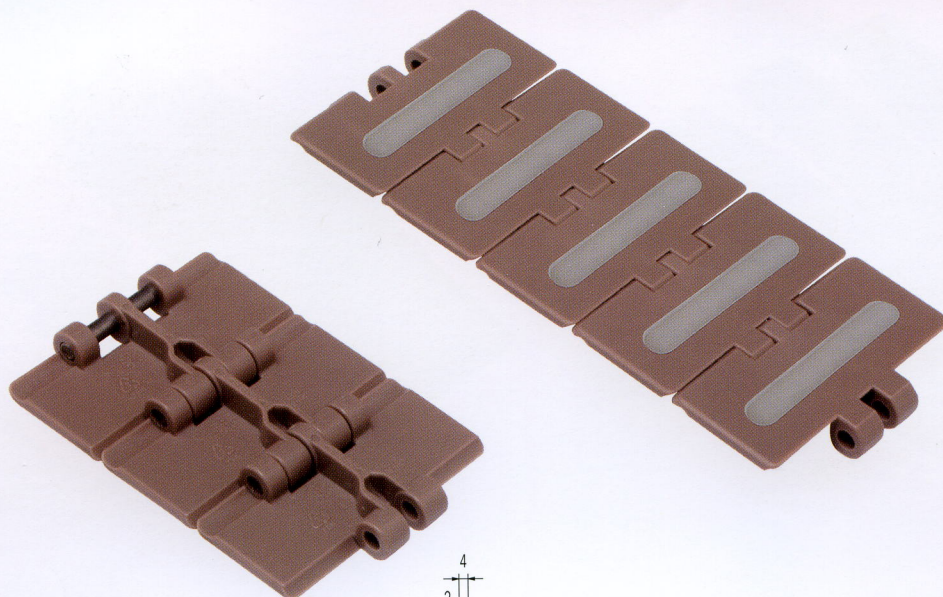

## HFL 820

### High Friction Link

- Plates in self-lubricating acetal resin, light brown-coloured, with rubber inserts.
- Pins in special chrome-nickel stainless steel, work hardened for high resistance.

Chain Ref.	Magris code	Link	Material	L	Width	B	Weight
			Antislip insert	mm.	mm.	mm.	Kg/m
HFL 820 - K 325*	G.6.10.040			82,5	65,0		0,83
HFL 820 - K 350*	G.6.10.060	LFA Acetal resin	Rubber	88,9	88,9		0,87
HFL 820 - K 400*	G.6.10.070	(Light brown)	60 Shore A	101,6	101,6		0,95
HFL 820 - K 450*	G.6.10.080		(Grey)	114,3	114,3		1,03
HFL 820 - K 600*	G.6.10.100			152,4	135,0		1,25

\*Size produced only upon request. Delivery conditions and terms to be agreed.

- Standard shipping lengths = 80 pitches = 10 feet = 3,048 metres.

- Special configurations of distance between inserts are available upon request. Delivery conditions and terms to be agreed.

- These chains can be supplied either with pins in austenitic stainless steel, work hardened, highly wear resistant, or with pins in thermoplastic resin.

# Thermoplastic straight running chains with rubber inserts - Double hinge

HFL 821 Series

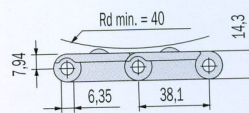
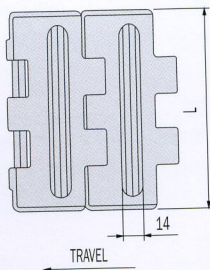
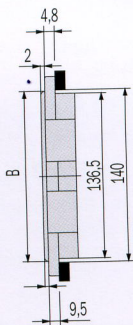
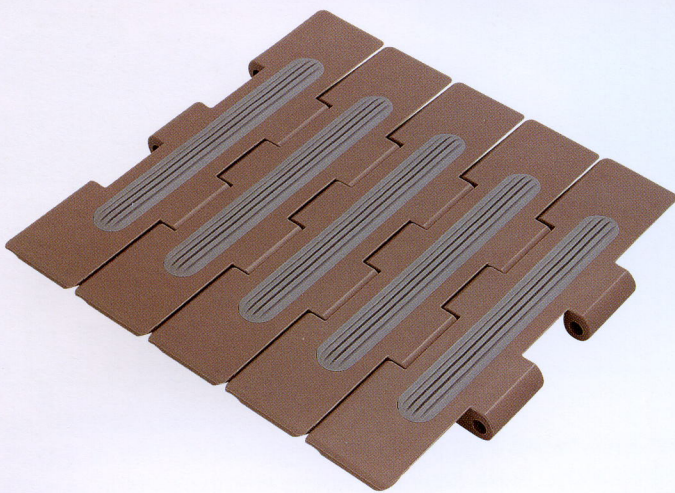

## HFL 821

### High Friction Link

- Plates in self-lubricating acetal resin, light brown-coloured, with rubber inserts.
- Pins in special chrome-nickel stainless steel, work hardened for high resistance.

Chain Ref.	Magris code	Link	Material	L	Width	B	Weight
			Antislip insert	mm.	mm.	mm.	Kg/m
HFL 821 - K 750*	G.6.14.110	LFA Acetal resin	Rubber	190,5	132,0	2,50	
HFL 821 - K 1000*	G.6.14.120	(Light brown)	60 Shore A	254,0	195,0	2,95	
HFL 821 - K 1200*	G.6.14.130		(Grey)	304,8	245,0	3,25	

\*Size produced only upon request. Delivery conditions and terms to be agreed.

- Standard shipping lengths = 80 pitches = 10 feet = 3,048 metres.

- Special configurations of distance between inserts are available upon request. Delivery conditions and terms to be agreed.

- These chains can be supplied with pins in austenitic stainless steel, work hardened, highly wear resistant.



## HFL 878 B0 Series

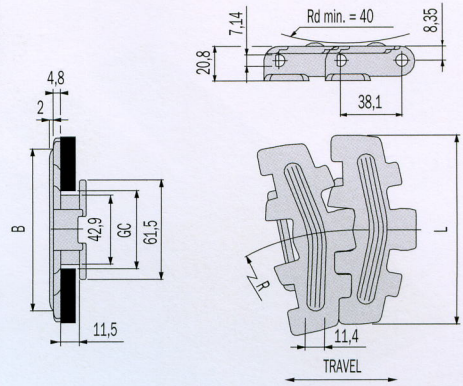
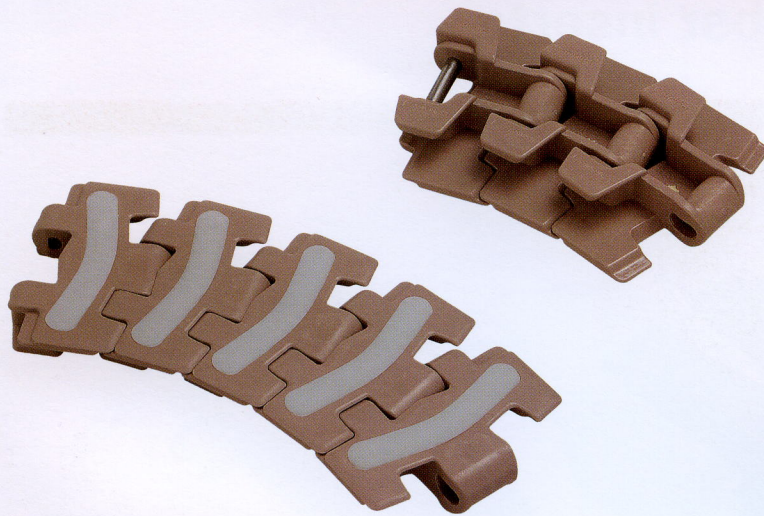

### HFL 878 B0

#### High Friction Link

- Plates in self-lubricating acetal resin, light brown-coloured, with rubber inserts.
- Pins in special chrome-nickel stainless steel, work hardened for high resistance.

Chain Ref.	Magris code	Material		L mm.	Width mm.	B mm.	Min. Radius R mm.	GC Straight mm.	GC Curve mm.	Weight Kg/m
		Link	Antislip insert							
HFL 878 B0 – K 325*	G.6.17.041	LFA Acetal resin	Rubber 60 Shore A	82,5	71	190	46	44,2	1,08	
HFL 878 B0 – K 450*	G.6.17.081	(Light brown)	(Grey)	114,3	102	190	46	44,2	1,20	

\*Size produced only upon request. Delivery conditions and terms to be agreed.

- Standard shipping lengths = 80 pitches = 10 feet = 3,048 metres.

- Special configurations of distance between inserts are available upon request. Delivery conditions and terms to be agreed.

- These chains can be supplied either with pins in austenitic stainless steel, work hardened, highly wear resistant, or with pins in thermoplastic resin.

## HFL 882 TAB Series

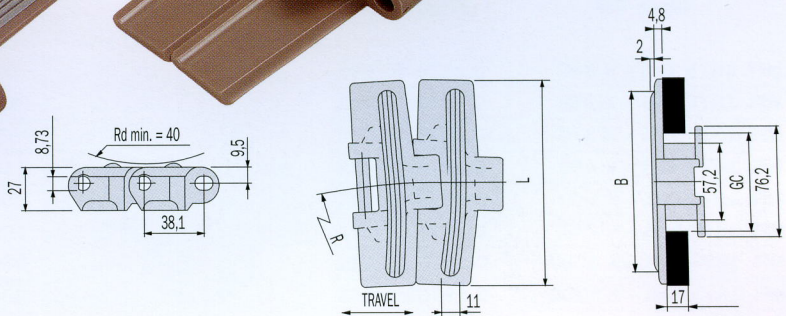
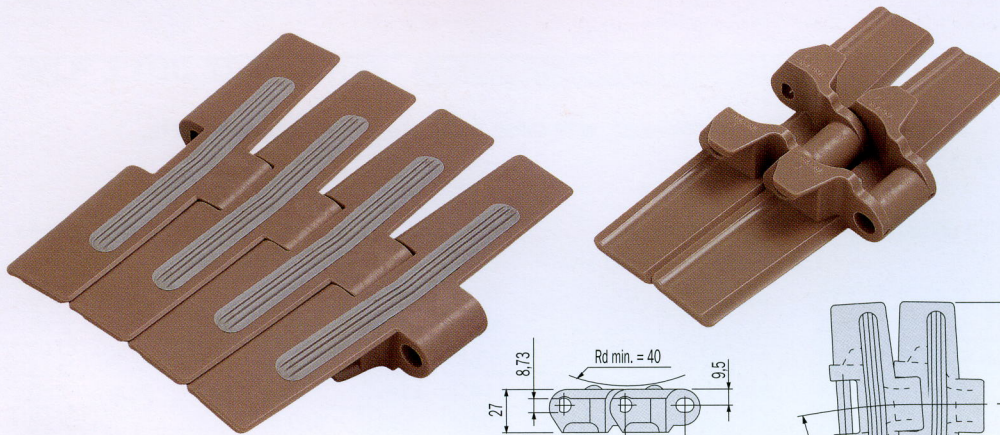

### HFL 882 TAB

#### High Friction Link

- Plates in self-lubricating acetal resin, light brown-coloured, with rubber inserts.
- Pins in special chrome-nickel stainless steel, work hardened for high resistance.

Chain Ref.	Magris code	Material		L mm.	Width mm.	B mm.	Min. Radius R mm.	GC Straight mm.	GC Curve mm.	Weight Kg/m
		Link	Antislip insert							
HFL 882 TAB – K 750*	G.6.15.111	LFA Acetal resin	Rubber 60 Shore A	190,5	132					2,43
HFL 882 TAB – K 1000*	G.6.15.121	(Light brown)	(Grey)	254,0	195	610	60	58		2,87
HFL 882 TAB – K 1200*	G.6.15.131			304,8	246					3,41

\*Size produced only upon request. Delivery conditions and terms to be agreed.

- Standard shipping lengths = 80 pitches = 10 feet = 3,048 metres.

- Special configurations of distance between inserts are available upon request. Delivery conditions and terms to be agreed.

- These chains can be supplied either with pins in austenitic stainless steel, work hardened, highly wear resistant, or with pins in thermoplastic resin.

# "1873" Sideflexing chains with thermoplastic Top Plates and rubber inserts

## HFL 1873 TAB Series

"1873" Sideflexing chains with thermoplastic Top Plates and rubber inserts

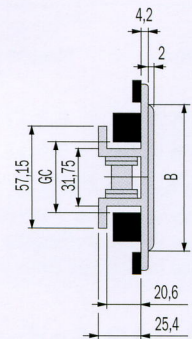
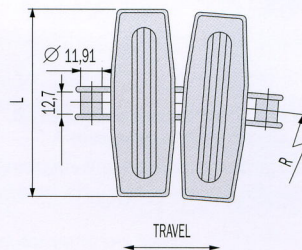
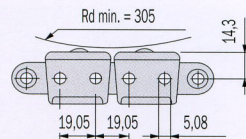
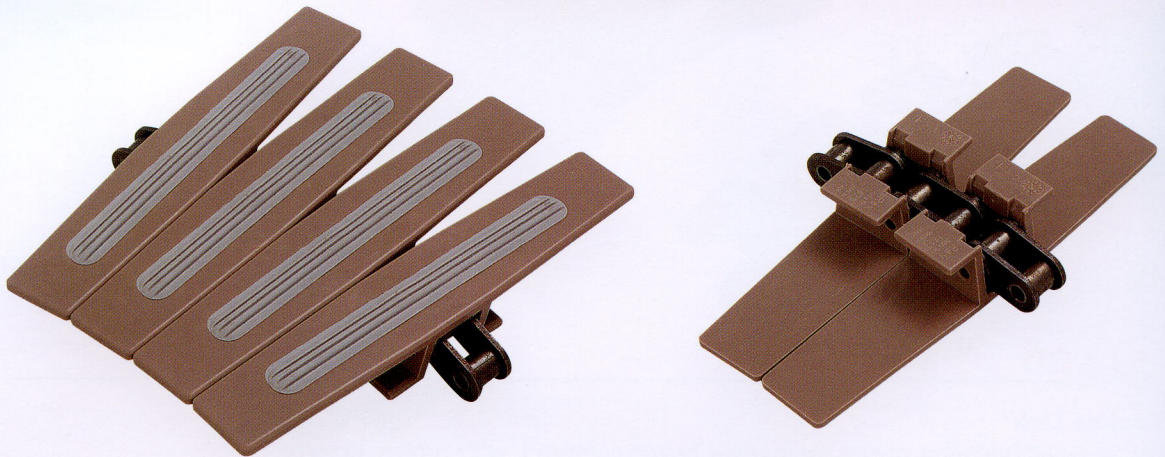

## HFL 1873 TAB

### High Friction Link

- Plates in self-lubricating acetal resin, light brown-coloured, with base roller chain and rubber inserts.
- Base roller chain, 19,05 mm - 3/4" pitch.

Chain Ref.	Magris code	Material	L	Width	B	Min. Radius R	GC Straight	GC Curve	Weight
		Base chain    Antislip insert	mm.	mm.	mm.	mm.	mm.	mm.	Kg/m
HFL 1873 TAB – K 325	G.1873.AC.041	Steel    LFA Acetal resin (Light brown)	82,5	82,5	457	33,3	34,6		2,60
HFL 1873 TAB – K 350	G.1873.AC.061		88,9	88,9	457				2,65
HFL 1873 TAB – K 375	G.1873.AC.065		95,2	95,2	457				2,70
HFL 1873 TAB – K 450	G.1873.AC.081		114,3	114,3	457				2,80
HFL 1873 TAB – K 600	G.1873.AC.101		152,4	132	457				2,90
HFL 1873 TAB – K 750	G.1873.AC.111		190,5	132	457				3,10
HFL 1873 TAB – K 1000	G.1873.AC.121		254,0	195	457				3,40
HFL 1873 TAB – K 1200	G.1873.AC.131		304,8	245	610				3,60
HFL 1873 TAB SS – K 325	G.1873.AS.041	Stainless Steel    LFA Acetal resin (Light brown)	82,5	82,5	457	33,3	34,6		2,60
HFL 1873 TAB SS – K 350	G.1873.AS.061		88,9	88,9	457				2,65
HFL 1873 TAB SS – K 375	G.1873.AS.065		95,2	95,2	457				2,70
HFL 1873 TAB SS – K 450	G.1873.AS.081		114,3	114,3	457				2,80
HFL 1873 TAB SS – K 600	G.1873.AS.101		152,4	132	457				2,90
HFL 1873 TAB SS – K 750	G.1873.AS.111		190,5	132	457				3,10
HFL 1873 TAB SS – K 1000	G.1873.AS.121		254,0	195	457				3,40
HFL 1873 TAB SS – K 1200	G.1873.AS.131		304,8	245	610				3,60

- Standard shipping lengths = 160 pitches = 10 feet = 3,048 metres.

- Special configurations of distance between inserts are available upon request. Delivery conditions and terms to be agreed.

# Biplanar thermoplastic chains

## WLF 1700 Series

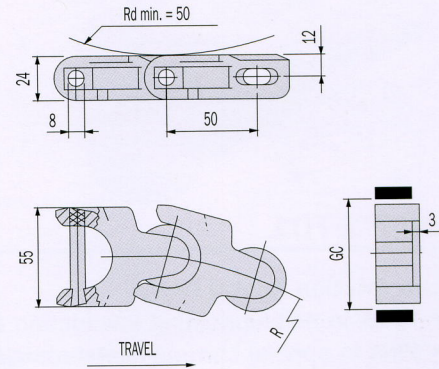
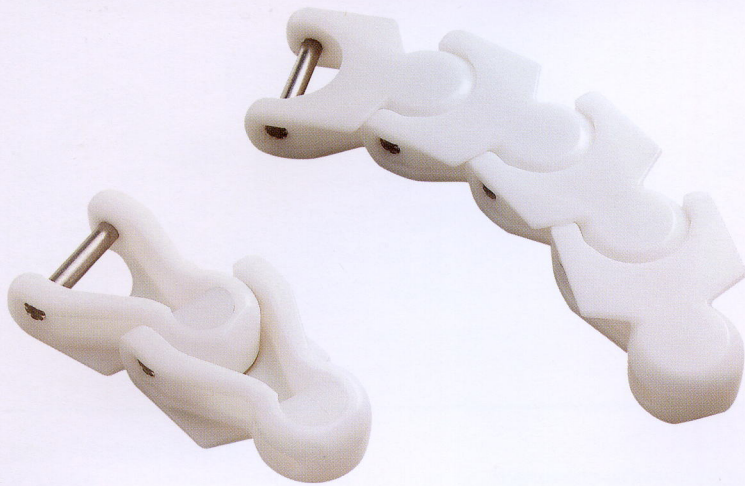

### WLF 1700

#### Low Friction Acetal Resin

- Links in self-lubricating low friction acetal resin, white-coloured.
- Pins in special chrome-nickel stainless steel, work hardened for high resistance.

Chain Ref.	Magris code	Material		Min. Radius R	GC Straight	GC Curve	Weight
		Link	Pin	mm.	mm.	mm.	Kg/m
<b>WLF 1700</b>	<b>1700.WA</b>	WLF Acetal resin (White)	Stainless Steel	140	58	-	1,26

- Standard shipping lengths = 122 pitches = 20 feet = 6,10 metres.

## WLF 1700 TAB Series

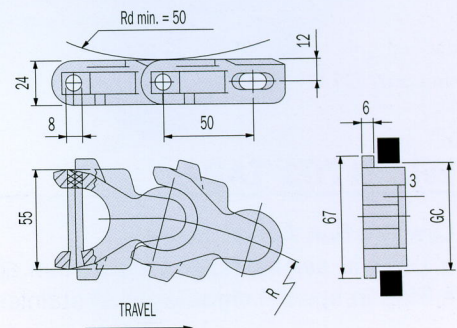
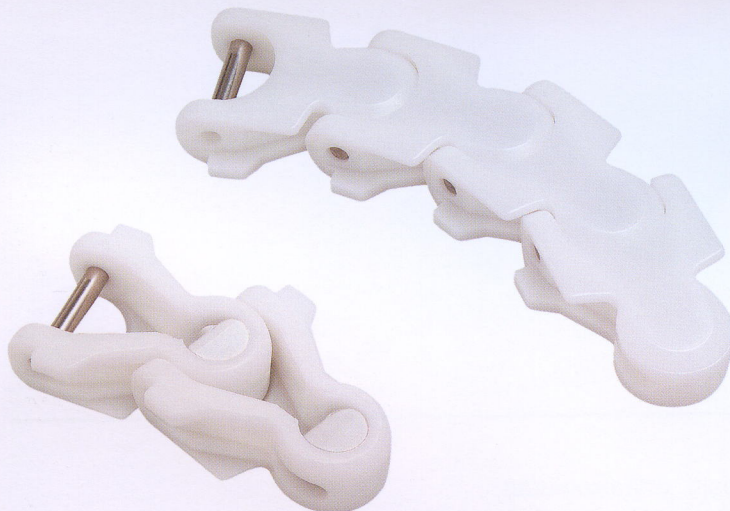

### WLF 1700 TAB

#### Low Friction Acetal Resin

- Links in self-lubricating low friction acetal resin, white-coloured.
- Pins in special chrome-nickel stainless steel, work hardened for high resistance.

Chain Ref.	Magris code	Material		Min. Radius R	GC Straight	GC Curve	Weight
		Link	Pin	mm.	mm.	mm.	Kg/m
<b>WLF 1700 TAB</b>	<b>1700.TAB.WA</b>	WLF Acetal resin (White)	Stainless Steel	140	58	58	1,30

- Standard shipping lengths = 122 pitches = 20 feet = 6,10 metres.



## WLF 1701 Series

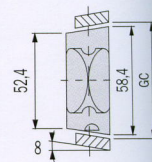
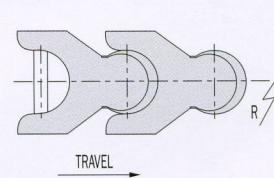
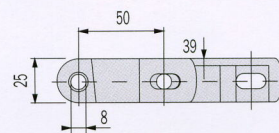

### WLF 1701

#### Low Friction Acetal Resin

- Links in self-lubricating low friction acetal resin, white-coloured.
- Pins in special chrome-nickel stainless steel, work hardened for high resistance.

Chain Ref.	Magris code	Material		Min. Radius R	GC Straight	GC Curve	Weight
		Link	Pin				
WLF 1701	1701.WA	WLF Acetal resin (White)	Stainless Steel	150	62	60,3	1,5

- Standard shipping lengths = 122 pitches = 20 feet = 6,10 metres.

## WLF 1701 TAB Series

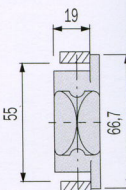
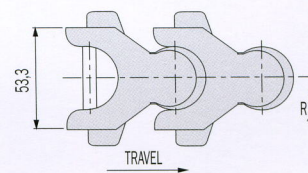
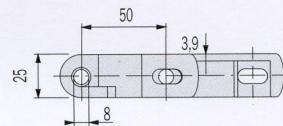

### WLF 1701 TAB

#### Low Friction Acetal Resin

- Links in self-lubricating low friction acetal resin, white-coloured.
- Pins in special chrome-nickel stainless steel, work hardened for high resistance.

Chain Ref.	Magris code	Material		Min. Radius R	GC Straight	GC Curve	Weight
		Link	Pin				
WLF 1701 TAB	1701.TAB.WA	WLF Acetal resin (White)	Stainless Steel	150	57,5	56,0	1,5

\* If R > 500, GC = 55

- Standard shipping lengths = 122 pitches = 20 feet = 6,10 metres.

# WLF 1702 Series

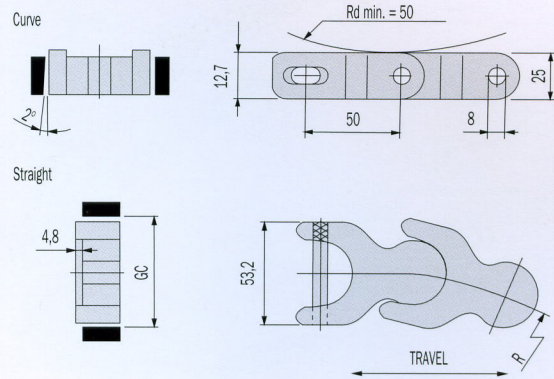

## WLF 1702

### Low Friction Acetal Resin

- Links in self-lubricating low friction acetal resin, white-coloured.
- Pins in special chrome-nickel stainless steel, work hardened for high resistance.

Chain Ref.	Magris code	Material		Min. Radius R	GC Straight	GC Curve	Weight
		Link	Pin				
<b>WLF 1702</b>	<b>1702.WA</b>	WLF Acetal resin (White)	Stainless Steel	140	59,5	56,8	1,43

- Standard shipping lengths = 122 pitches = 20 feet = 6,10 metres.

# Case conveyor chains

## D 600 Series

Case conveyor chains

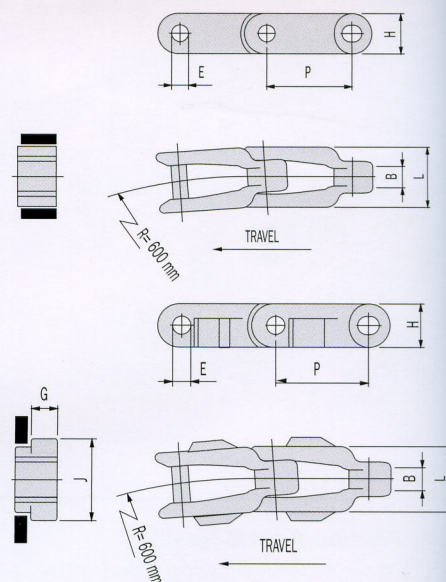
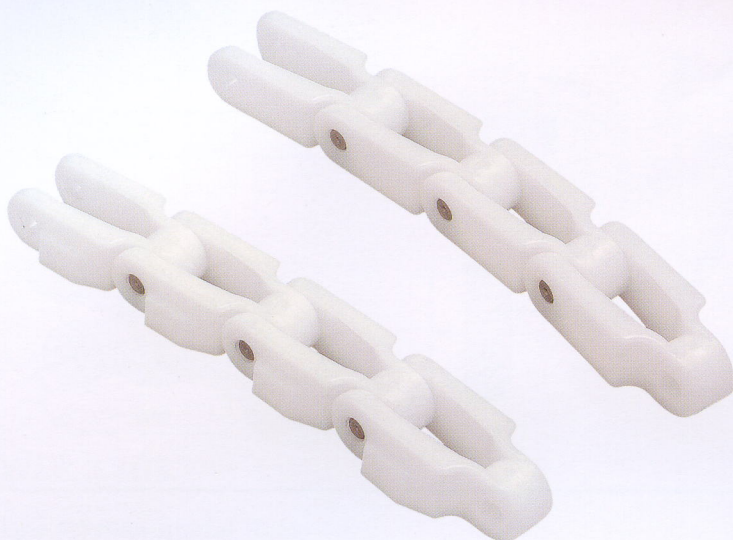

### D 600 - D 600 TAB

#### Acetal Resin

- Links in self-lubricating acetal resin, white-coloured.
- Pins in special chrome-nickel stainless steel, work hardened for high resistance.

Chain Ref.	Magris code	Material	Pitch P mm.	Width L mm.	Pin Diameter E mm.	Max Sprocket Face B mm.	Depth of sidebar H mm.	Width Over Lug J mm.	Height of Lug G mm.	Weight Kg/m
D 600	600.D	Acetal	63,5	43	11	14,3	29	-	-	1,44
D 600 TAB	600.TAB.D	Acetal	63,5	43	11	14,3	29	54	15	1,49

- Standard shipping lengths 96 pitches = 20 feet = 6,096 metres.

## D 600 C Series

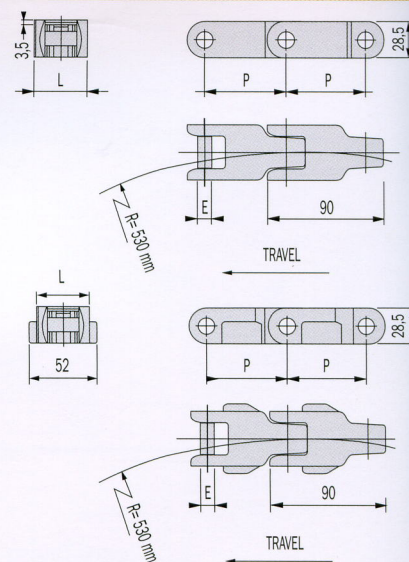

### D 600 C - D 600 TAB C

#### Acetal Resin

- Links in self-lubricating acetal resin, white-coloured.
- Pins in special chrome-nickel stainless steel, work hardened for high resistance.

Chain Ref.	Magris code	Material	Pitch P mm.	Width L mm.	Pin Diameter E mm.	Max Sprocket Face B mm.	Depth of sidebar H mm.	Width Over Lug J mm.	Height of Lug G mm.	Weight Kg/m
D 600 C	600.D.C	Acetal	63,5	43	11	14,3	29	-	-	1,42
D 600 TAB C	600.TAB.D.C	Acetal	63,5	43	11	14,3	29	52	15	1,55

- Standard shipping lengths 96 pitches = 20 feet = 6,096 metres.

## D 1400 Series

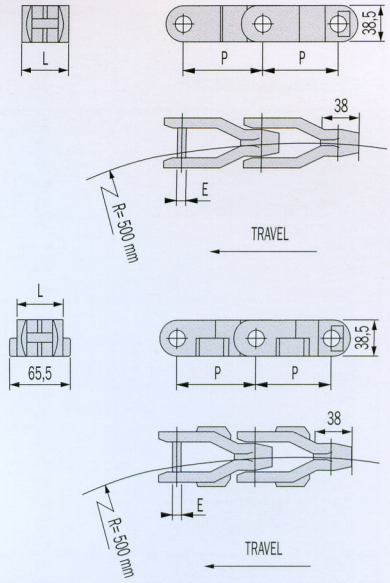
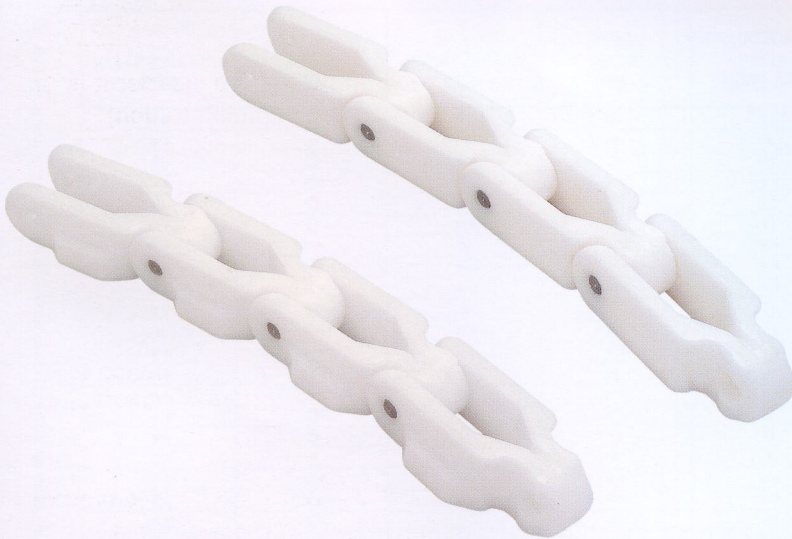

### D 1400 - D 1400 TAB

#### Acetal Resin

- Links in self-lubricating acetal resin, white-coloured.
- Pins in special chrome-nickel stainless steel, work hardened for high resistance.

Chain Ref.	Magris code	Material	Pitch P mm.	Width L mm.	Pin Diameter E mm.	Max Sprocket Face B mm.	Depth of sidebar H mm.	Width Over Lug J mm.	Height of Lug G mm.	Weight Kg/m
<b>D 1400</b>	<b>1400.D</b>	Acetal	82,5	50	9,5	15,9	38	-	-	1,44
<b>D 1400 TAB</b>	<b>1400.TAB.D</b>	Acetal	82,5	50	9,5	15,9	38	66	19	2,26

- Standard shipping lengths 74 pitches = 20 feet = 6,105 metres.

# Plastic corrosion resistance table

0= Little resistance, not recommended •= Average resistance ••= Good resistance, it can be used

Plastic corrosion resistance table

CHEMICAL AGENT	ACETAL RESIN D	ACETAL RESIN LFA/WLF	ACETAL RESIN SP	SPECIAL ACETAL RESIN WR	ANTISTATIC RESIN AS	POLYPROPYLENE PPB
Acetic acid	0	0	0	••	0	••
Acetone	•	•	•	••	•	••
Aluminium chloride	0	0	0	••	0	0
Ammonia	••	••	••	••	••	••
Ammonium chloride	0	0	0	••	0	0
Amyl alcohol	0	0	0	••	0	••
Aniline	••	••	••	•	••	••
Beer	••	••	••	••	••	••
Benzene	••	••	••	••	••	••
Benzoic acid	0	0	0	•	0	••
Benzol	••	••	••	••	••	•
Boric acid	••	••	••	••	••	••
Brine	•	•	•	•	•	••
Butter	••	••	••	••	••	••
Butyl alcohol	0	0	0	••	0	••
Butyric Acid	0	0	0	0	0	••
Calcium chloride	•	•	•	••	•	••
Carbon disulphide	••	••	••	••	••	••
Carbon tetrachloride	••	••	••	••	••	0
Caustic soda (20%)	0	0	0	••	0	••
Cheese	••	••	••	0	••	••
Chlorine water	0	0	0	••	0	0
Chloroform	0	0	0	0	0	•
Citric acid	•	•	•	•	•	••
Copper sulphate	••	••	••	••	••	••
Diet oil	••	••	••	••	••	••
Diet fat	••	••	••	••	••	••
Distilled water	••	••	••	••	••	••
Ethyl acetate	0	0	0	••	0	••
Ethyl alcohol	••	••	••	••	••	••
Ethyl chloride	••	••	••	••	••	0
Ethyl ether	••	••	••	••	••	••
Flax oil	0	0	0	••	0	••
Formaldehyde	••	••	••	••	••	••
Formic acid	0	0	0	0	0	••
Freon 12	0	0	0	••	0	0
Fresh water	••	••	••	••	••	••
Fruit juice	••	••	••	••	••	••
Gasoline	••	••	••	••	••	•
Glycerine	••	••	••	••	••	••
Hydrochloric acid	0	0	0	0	0	••
Hydrofluoric acid	0	0	0	0	0	••
Hydrogen peroxide	0	0	0	0	0	••
Iodine	••	••	••	0	••	••
Iron chloride	0	0	0	••	0	••
Lactic acid	••	••	••	••	••	••
Magnesium chloride	0	0	0	••	0	••
Mercury	••	••	••	••	••	••
Methyl alcohol	••	••	••	••	••	••
Methylene chloride	0	0	0	••	0	•
Milk	••	••	••	••	••	••
Nitric acid	0	0	0	0	0	••
Oil	••	••	••	••	••	•
Oil ether	••	••	••	••	••	•
Oleic acid	0	0	0	••	0	••
Paraffin	••	••	••	0	••	•
Phenol	0	0	0	0	0	••
Phosphoric acid	0	0	0	••	0	••
Potassium hydroxide	0	0	0	••	0	0
Sea water	•	•	•	••	•	••
Silicone oil	0	0	0	••	0	••
Silver nitrate	0	0	0	••	0	••
Soapy water	••	••	••	••	••	••
Sodium carbonate	••	••	••	••	••	••
Sodium chloride	••	••	••	••	••	••
Sodium hydroxide	••	••	••	••	••	••
Sodium hypochlorite	0	0	0	••	0	••
Sodium silicate	0	0	0	••	0	0
Sodium sulphate	••	••	••	••	••	••
Soft drinks	••	••	••	••	••	••
Suds	0	0	0	••	0	••
Sulphuric acid	0	0	0	0	0	••
Tartaric acid	•	•	•	••	•	••
Tetraline	0	0	0	••	0	0
Tincture of iodine	••	••	••	0	••	••
Transformer oil	0	0	0	••	0	•
Trichloroethylene	0	0	0	•	0	•
Turpentine	0	0	0	•	0	0
Vegetable juice	••	••	••	••	••	••
Vegetable oil	••	••	••	••	••	••
Vinegar	••	••	••	••	••	••
Whisky	••	••	••	••	••	••
Wine	••	••	••	••	••	••
Xilol	••	••	••	••	••	0
Zinc chloride	0	0	0	•	0	••

The indicated data are approximate as the corrosion resistance of the plastic materials, according to the conditions of use, is related to working temperatures, the concentration of the chemical agent, the duration of the contact with it, etc.



**MAGRIS**

Magris s.r.l. - P.O. Box 71 - Via Vanizza, 10 (z.i. Sarano) - 31025 S. Lucia di Piave (TV) Italy  
Tel. +39 0438 460226 - Fax +39 0438 701843 - E-mail: [magris@magris.com](mailto:magris@magris.com) - [www.magris.com](http://www.magris.com)